

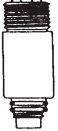

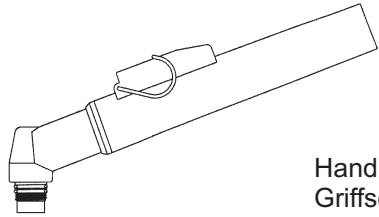

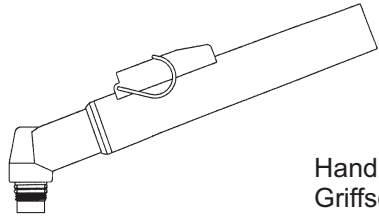









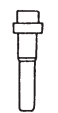







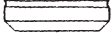
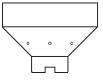
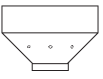









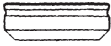
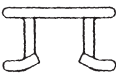

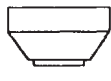
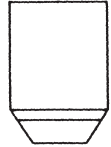





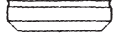

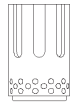







Ref.-Nr.	Bestell-Nr.	Artikelbezeichnung	
<b>Verschleissteile passend für Hypertherm® Max® 40 / HT® 40 (PAC 140)</b>			
057112 057113 057053 057054	HG 1226 HG 1285 HG 1227 HG 1286	Handbrenner, 25' - 7,5 m (1/2 - 20 Anschluss) ..... Handbrenner, 50' - 15,0 m (1/2 - 20 Anschluss) ..... Maschinenbrenner, 25' - 7,5 m mit abgeschirmten Kabel Maschinenbrenner, 50' - 15,0 m mit abgeschirmten Kabel	
	HG 1206 HG 1207 HG 1208 HG 1209	 Brennerkabel, 25' - 7,5 m (f. Handbrenner) ..... Brennerkabel, 50' - 15,0 m (f. Handbrenner) ..... Brennerkabel, 25' - 7,5 m (f. Maschinenb.) Abgeschirmt... Brennerkabel, 50' - 15,0 m (f. Maschinenb.) Abgeschirmt...	
020206 020114	HG 1229F HG 1229	 Führungsrohr ..... Maschinenbrennerkörper .....	
026016	HG 1221	 O-Ring passend für Hand- u. Maschinenbrennerkörper	
057114	HG 1228	 Handbrennerkörper komplett mit Griffschale und Mikroschalter .....	
020103	HG 1021	 Elektrode Hafnium .....	
020101	HG 1225	 Luftverteiler VESPEL® .....	
020115	HG 1003	 Düse (Handbrenner) .....	
020131	HG 1004	 Konische Düse (Maschinenbrenner) .....	
020102	HG 1222	 Düse (Maschinenbrenner) .....	
020104	HG 1220	 Düsenhalter .....	
020467	HG 1025	 Lange Elektrode Hafnium .....	
020466	HG 1023	 Lange Düse .....	
020200	HG 1224	 Düsenhalter .....	
Das dazugehörige Kreisschneideset und Zubehör finden Sie auf der Seite 3.			
Die Bezeichnungen "Hypertherm" sowie "Max" sind eingetragene Warenzeichen der Hypertherm Inc. N.H. USA. Sie werden hier nur aus Referenzgründen genannt.			
© Copyright 2010 by HOLMA® Switzerland. Alle Rechte vorbehalten.			
			<b>Seite 21</b>

Ref.- Nr.	Bestell-Nr.	Artikelbezeichnung	
<b>Verschleisssteile passend für Hypertherm® Powermax 600® (PAC123T/M)</b>			
120576	HG 12311	 Luftverteiler Vespel® .....	
120573	HG 12300	 Elektrode Hafnium, long life..... (ersetzt 020351)	
120826	HG 12342	 Düse 40 Amp.....	
120574	HG 12303	 Lange Elektrode Hafnium..... (ersetzt 020547)	
120606	HG 12313	 Spitze Düse 35 Amp PAC 123 T .....	
120600	HG 12315	 Düsenhalter PAC 123 T/M.....(HOLMA Design).....	
120303	HG 3111/1	 Deflektor PAC 123 T/M (HOLMA Design).....	
120828	HG 12340	 Düsenkontaktschutz (für Handschneiden)..... PAC 123 T/M.....(HOLMA Design).....	
120827	HG 12341	 Düsenkontaktschutz (für Maschinenschneiden)..... PAC 123 T/M.....(HOLMA Design).....	
<p>Das dazugehörige Kreisschneideset und Zubehör finden Sie auf der Seite 3. Die Bezeichnungen "Hypertherm" sowie "Max" sind eingetragene Warenzeichen der Hypertherm Inc. N.H. USA. Sie werden hier nur aus Referenzgründen genannt.</p>			
<b>Seite 22</b>		<b>© Copyright 2010 by HOLMA® Switzerland. Alle Rechte vorbehalten.</b>	

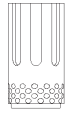
Ref.- Nr.	Bestell-Nr.	Artikelbezeichnung	
<b>Verschleisssteile passend für Hypertherm® Powermax 800® (PAC121TS/M)</b>			
020361	HG 1260	 Luftverteiler Vespel® .....	
120573	HG 12300	 Elektrode Hafnium, long life..... (ersetzt 020351)	
120438 120282	HG 12301 HG 12302	 Düse 40 Amp PAC 121T/M.....  Düse 50 Amp PAC 121T/M.....	
020395	HG 1212	 Düse 50 Amp PAC 121 T.....	
120574	HG 12303	 Lange Elektrode Hafnium..... (ersetzt 020547)	
120305	HG 12305	 Spitze Düse PAC 121 T/M.....	
120304	HG 12304	 Lange Düse PAC 121 T.....	
120301	HG 12306	 Düsenhalter PAC 121 T/M.....(HOLMA Design).....	
	HG 3111	 Deflektor.....(HOLMA Design).....	
	HG 12309	 Abstandsfeder.....	
120283	HG 12307	 Düsenkontaktschutz (für Handschneiden)..... .....(HOLMA Design).....	
120326	HG 12308	 Düsenkontaktschutz (für Maschinenschneiden)..... .....(HOLMA Design).....	
020930	HG 1257	 Düsenhalter.....(HOLMA Design).....	
<p>Das dazugehörige Kreisschneideset und Zubehör finden Sie auf der Seite 3.</p> <p>Die Bezeichnungen "Hypertherm" sowie "Powermax" sind eingetragene Warenzeichen der Hypertherm Inc. N.H. USA. Sie werden hier nur aus Referenzgründen genannt.</p> <p>© Copyright 2010 by HOLMA® Switzerland. Alle Rechte vorbehalten.</p>			

Ref.- Nr.	Bestell-Nr.	Artikelbezeichnung
<b>Verschleissteile passend für Hypertherm® Powermax 900® (PAC125T/M)</b>		
120576	HG 12311	 Luftverteiler Vespel® .....
120573	HG 12300	 Elektrode Hafnium, long life..... (ersetzt 020351)
120577	HG 12312	 Düse 55 Amp PAC 125 T/M.....
120574	HG 12303	 Lange Elektrode Hafnium..... (ersetzt 020547)
120606 120578	HG 12313 HG 12314	 Spitze Düse 35 Amp PAC 125 T ..... Lange Düse 55 Amp PAC 125 T .....
120600	HG 12315	 Düsenhalter PAC 125 T/M.....(HOLMA Design).....
120303	HG 3111/1	 Deflektor PAC 125 T/M (HOLMA Design).....
120601	HG 12307	 Düsenkontaktschutz (für Handschneiden)..... PAC 125 T.....(HOLMA Design).....
120602	HG 12308	 Düsenkontaktschutz (für Maschinenschneiden)..... PAC 125 M .....(HOLMA Design).....
<p>Das dazugehörige Kreisschneideset und Zubehör finden Sie auf der Seite 3.</p> <p>Die Bezeichnungen "Hypertherm" sowie "Max" sind eingetragene Warenzeichen der Hypertherm Inc. N.H. USA. Sie werden hier nur aus Referenzgründen genannt.</p> <p>© Copyright 2010 by HOLMA® Switzerland. Alle Rechte vorbehalten.</p>		

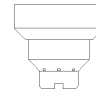
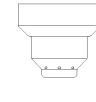
Ref.- Nr.	Bestell-Nr.	Artikelbezeichnung	
<b>Verschleissteile passend für Hypertherm®            Powermax 1000/1100/1250/1650®, T60/T60M®,            RT60/RT60M®, T80/T80M®, RT80/RT80M®, T100/T100M®</b>			
120925	HG 12350	 Luftverteiler Vespel® (40-80A).....	
120926	HG 12351	 Elektrode Hafnium (40-80A).....	
120932 120931 120927	HG 12355 HG 12356 HG 12357	 Düse 40A .....  Düse 60A .....  Düse 80A .....	
220329	HG 12358	 FineCut Düse Chrom T60/T80/T100.....	
220006	HG 12359	 Lange Düse 40 Amp. .... <b>NEU!!</b>	
220007 120980	HG 12349 HG 12348	 Lange Düse 60 Amp. .... <b>NEU!!</b>  Lange Düse 80 Amp. ....	
120928	HG 12352	 Düsenhalter (40-80A).....	
120929	HG 12353	 Düsenkontaktschutz (Handschneiden 40-80A)..... (HOLMA Design)	
120930	HG 12354	 Düsenkontaktschutz (Maschinenschneiden 40-80A)..... (HOLMA Design)	
220051	HG 12360	 Luftverteiler Vespel® (100A).....	
220037	HG 12361	 Elektrode Hafnium (100A).....	
220011	HG 12365	 Düse 100A .....	
220048	HG 12362	 Düsenhalter (100A).....	
220065	HG 12363	 Düsenkontaktschutz (Handschneiden 100A)..... (HOLMA Design)	
220047	HG 12364	 Düsenkontaktschutz (Maschinenschneiden 100A) ..... (HOLMA Design)	

## Verschleissteile passend für Hypertherm® MAX® 80 / 100 (PAC 130)

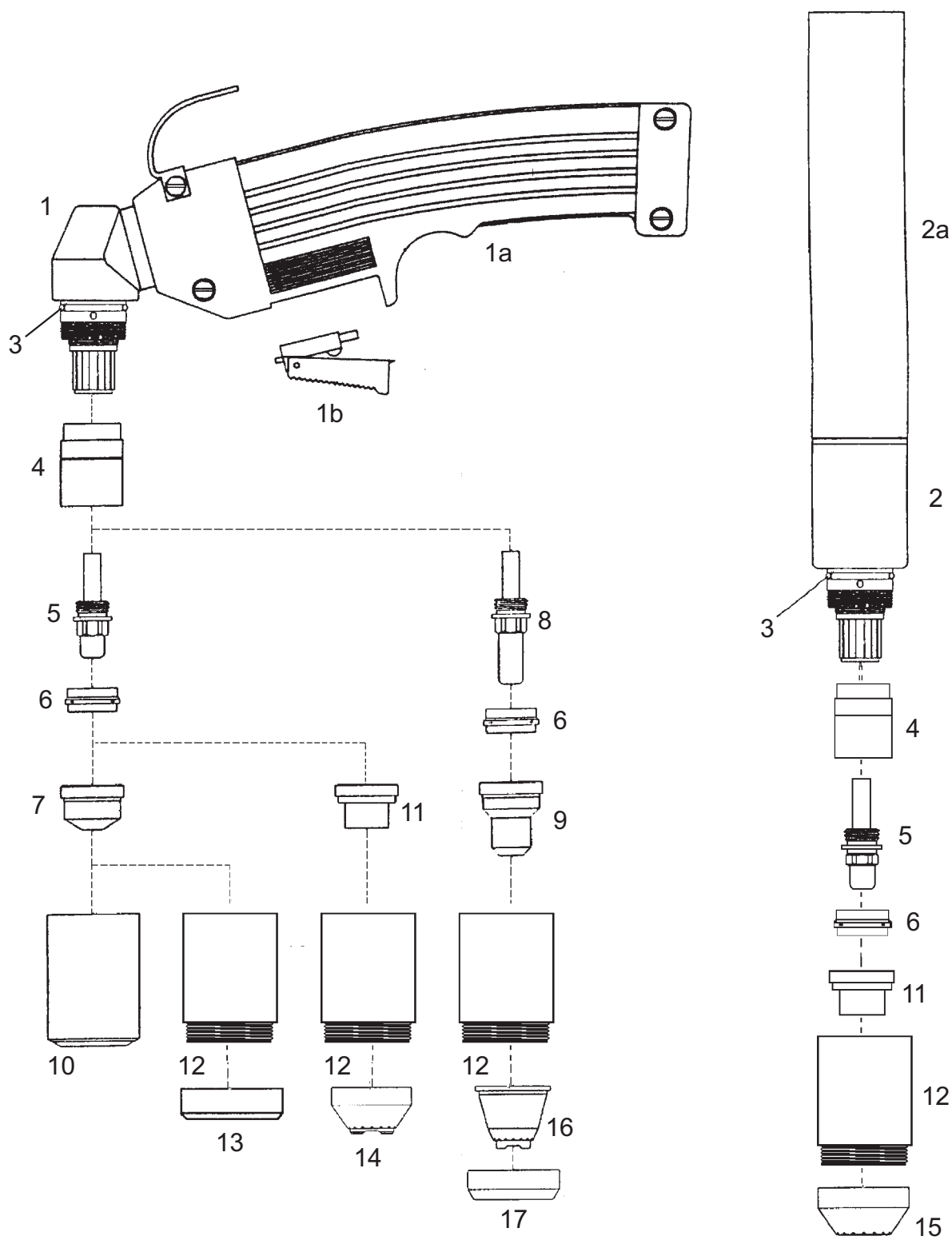





Die Bezeichnungen "HYPERTHERM" sowie "MAX" sind eingetragene Warenzeichen der Hypertherm Inc. N. H. USA. Sie werden hier nur aus Referenzgründen genannt.



Nr.	Ref-Nr.	Bestell-Nr.	Artikelbezeichnung
	059076	HG 1245	Handbrenner kpl. 25' - 7,5 m (1/2 - 20 Anschluss).....
	059077	HG 1246	Handbrenner kpl. 50' - 15,0 m (1/2 - 20 Anschluss).....
	059008	HG 1247	Maschinenbrenner kpl. 25' - 7,5 m (1/2 - 20 mit abgeschirmtem Kabel)..
	059009	HG 1248	Maschinenbrenner kpl. 50' - 15,0 m (1/2 - 20 mit abgeschirmtem Kabel)..
		HG 1258	Brennerkabel 25' - 7,5 m (1/2 - 20 Anschluss) für Handbrenner.....
		HG 1259	Brennerkabel 50' - 15,0 m (1/2 - 20 Anschluss) für Handbrenner.....
		HG 1261	Brennerkabel 25' - 7,5 m (1/2 - 20 Anschluss) abgeschirmt f. Maschinenbr.
		HG 1262	Brennerkabel 50' - 15,0 m (1/2 - 20 Anschluss) abgeschirmt f. Maschinenbr.
1	020189	HG 1242	Handbrennerkörper mit Griffschale und Mikroschalter.....
1a		HG 1026/5	Griffschale komplett mit Mikroschalter.....
1b		HG 1026/6	Mikroschalter.....
2	020201	HG 1243	Maschinenbrennerkörper.....
2a	020245	HG 3009	Führungsrohr.....
3	026018	HG 2648	O - Ring.....
4		HG 1043V	Einsatz aus VESPEL® .....
5	120433	HG 1230	Elektrode Hafnium, long life (alte Ref Nr. 020191).....
6	020194	HG 1231	Luftverteiler VESPEL® .....
7	020203	HG 1232	Düse Ø 1,0 mm -.038 40 Amp.....
	020345	HG 1233	Düse Ø 1,3 mm -.052 80 Amp.....
	020195	HG 1234	Düse Ø 1,5 mm -.059 100 Amp.....
	020705	HG 1254	Düse 100 Amp passend für Hypertherm® MAX100D.....
8	020564	HG 1239	Lange Elektrode, Hafnium.....
9		HG 12401	Lange Düse Ø 1,0 mm -.038 .....
	020563	HG 1240	Lange Düse Ø 1,4 mm -.055 .....
10	020184	HG 1235	Düsenhalter.....
11	020396	HG 1293	Kontaktdüse Ø 1,0 mm -.038 40 Amp.....
	020397	HG 1241	Kontaktdüse Ø 1,3 mm -.052 80 Amp.....
	020337	HG 1284	Kontaktdüse Ø 1,5 mm -.059 100 Amp.....
12		HG 1237	Kontaktdüsenhalter HOLMA.-Produkt.....
	020336	HG 1292	Kontaktdüsenhalter mit VESPEL® HOLMA-Produkt.....
13	020333	HG 1253	Deflektor.....
14	020335	HG 1295	Düsenkontaktschutz für Handschneiden HOLMA-Design.....
15	020334	HG 1298	Düsenkontaktschutz für Maschinenschneiden HOLMA-Design.....
16		HG 1296	Düsenkontaktschutz für Handschneiden (für lange Düsen Abb.Nr.11).....
17		HG 1297	Überwurfmutter.....

Die Bezeichnungen "Hypertherm" sowie "Max" sind eingetragene Warenzeichen der Hypertherm Inc. N.H. USA. Sie werden hier nur aus Referenzgründen genannt.



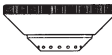

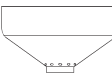

© Copyright 2010 by HOLMA® Switzerland. Alle Rechte vorbehalten.

Seite 27

Ref.-Nr.	Bestell-Nr.	Artikelbezeichnung
<b>Verschleissteile passend für Hypertherm® Max 200®, PAC200T/E und HT 2000®</b>		
120547	HG 30134	 Elektrode - Sauerstoff 100A..... Elektrode - Sauerstoff 200A (ers. 020664/020414/220021). <b>NEU!!</b> Elektrode - Sauerstoff 200A <b>HOLMA BLUE LINE</b> ..... Elektrode - Ar/H 200A.....
120667	HG 30035	
120667	HG 30035/B	
020415	HG 30133	
020689	HG 30074	 Düse - .038, 40 Amp Luft.....
020616	HG 30062	 Düse - .055, 100 Amp Sauerstoff (MAX 200®)..... Düse - .059, 100 Amp Luft/Stickstoff .....
020611	HG 30058	
020605	HG 30055	 Düse - .082, 200 Amp Sauerstoff..... Düse - .086, 200 Amp Luft/Stickstoff..... Düse - .055, 100 Amp Sauerstoff (HT 2000®)..... Fugenhobeldüse Luft 200A .....
020608	HG 30057	
020690	HG 30075	
020615	HG 30112	
020423	HG 30040	 Düsenhalter .....
020424	HG 30041	 Schutzkappe - .086, 200 Amp, Maschinenbrenner..... Schutzkappe - .059, 100 Amp, Maschinenbrenner.....
020448	HG 30045	

<b>Verschleissteile passend für Hypertherm® Hyspeed® HT 2000®</b>		
220235	HG 30150	 Elektrode 200A O <sub>2</sub> .....
220237	HG 30155	 Düse 200A O <sub>2</sub> .....
220238	HG 30158	 Düsenhalter 200A O <sub>2</sub> .....
220239	HG 30159	 Schutzkappe 200A O <sub>2</sub> .....

Die Bezeichnungen "Hypertherm" sowie "Max" sind eingetragene Warenzeichen der Hypertherm Inc. N.H. USA. Sie werden hier nur aus Referenzgründen genannt.

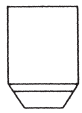
Ref.- Nr.	Bestell-Nr.	Artikelbezeichnung	
<b>Verschleissteile passend für Hypertherm® Max® 40CS, Max® 42, Max® 43 (PAC 121PT/M)</b>			
020361	HG 1260	 Luftverteiler VESPEL® .....	
120573	HG 12300	 Elektrode Hafnium, long life..... (Alte Ref.-Nr. 020351)	
020350 020395	HG 1211 HG 1212	 Düse Ø 0,96 - .038..... Düse Ø 1,06 - .042.....	
020542	HG 1218	 Konische Düse .....	
120574	HG 12303	 Lange Elektrode Hafnium..... (Alte Ref.-Nr. 020547)	
020546	HG 1214	 Lange Düse Ø 0,96 - .038 .....	
020930	HG 1257	 Düsenhalter .....	