

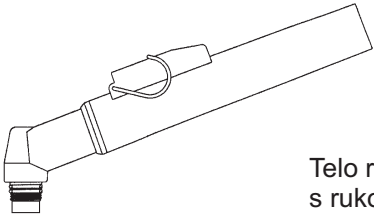























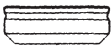











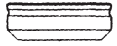



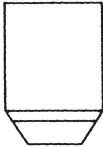





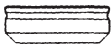









Ref.cislo	Obj.cislo	Popis
		Spotrebne diely vhodne pre Hypertherm® Max® 40 / HT® 40 (PAC 140)
057112	HG 1226	Rucny horak, 25' - 7,5 m (1/2 - 20).....
057113	HG 1285	Rucny horak, 50' - 15,0 m (1/2 - 20)
057053	HG 1227	Strojny horak, 25' - 7,5 m s izolovanim kablom.....
057054	HG 1286	Strojny horak, 50' - 15,0 m s izolovanim kablom.....
	HG 1206	 Kabel, 25' - 7,5 m (na rucny horak) Kabel, 50' - 15,0 m (na rucny horak) Kabel, 25' - 7,5 m (na str.horak) izolovany..... Kabel, 50' - 15,0 m (na str.horak) izolovany.....
	HG 1207	
	HG 1208	
	HG 1209	
	HG 1229F	
020206	HG 1229	Dopravna trubica.....
020114	HG 1229	Telo strojneho horaka.....
026016	HG 1221	 O-kruzok vhodny na telo stroj. horaka.....
057114	HG 1228	Telo rucneho horaka kompletne s rukovätou so spinacom.....
020103	HG 1021	 Elektroda Hafnium
020101	HG 1225	 Rozvadzac vzduchu VESPEL®
020115	HG 1003	 Tryska (rucny horak)
020131	HG 1004	 Konicka tryska (strojny horak)
020102	HG 1222	 Tryska (strojny horak)
020104	HG 1220	 Drziak trysky.....
020467	HG 1025	 Predlzena elektroda Hafnium
020466	HG 1023	 Predlzena tryska
020200	HG 1224	 Drziak trysky
		Supravy na kruhove rezanie s prislusenstvom najdete na str.3
		Oznacenia "Hypertherm" ako aj "Max" su registrovane obchodne oznacenia firmy Hypertherm Inc. N.H. USA. V nasom katalogu su uvedene len z orientacnych dovodov.
		© Copyright 2009 by HOLMA® Switzerland. Vsetky prava vyhradene.

Ref.cislo	Obj.cislo	Popis
Spotrebne diely vhodne pre Hypertherm® Powermax 600® (PAC123T/M)		
120576	HG 12311	 Rozvadzac vzduchu Vespele®
120573	HG 12300	 Elektroda Hafnium, long life..... (nahradi 020351)
120826	HG 12342	 Tryska 40 Amp.....
120574	HG 12303	 Predlzena elektroda Hafnium..... (nahradi 020547)
120606	HG 12313	 Tryska s hrotom 35 Amp PAC 123 T
120600	HG 12315	 Drziak trysky PAC 123 T/M.....(HOLMA Design)....
120303	HG 3111/1	 Deflektor PAC 123 T/M (HOLMA Design)....
120828	HG 12340	 Kontaktna krytka (na rucne rezanie)..... PAC 123 T/M.....(HOLMA Design)....
120827	HG 12341	 Kontaktna krytka (na strojne rezanie)..... PAC 123 T/M.....(HOLMA Design)....
Supravy na kruhove rezanie s prislusenstvom najdete na str. 3		
Oznacenia "Hypertherm" ako aj "Max" su registrovane obchodne oznacenia firmy Hypertherm Inc. N.H. USA. V nasom katalogu su uvedene len z orientacnych dovodov.		
Strana 22	© Copyright 2009 by HOLMA® Switzerland.Vsetky prava vyhradene.	

Ref.cislo	Obj.cislo	Popis
Spotrebne diely vhodne pre Hypertherm® Powermax 800® (PAC121TS/M)		
020361	HG 1260	 Rozvadzac vzduchu Vespel®.....
120573	HG 12300	 Elektroda Hafnium, long life..... (nahradi 020351)
120438 120282	HG 12301 HG 12302	 Tryska 40 Amp PAC 121T/M.....  Tryska 50 Amp PAC 121 T.....
020395	HG 1212	 Tryska 50 Amp PAC 121 T.....
120574	HG 12303	 Predlzena elektroda Hafnium..... (nahradi 020547)
120305	HG 12305	 Tryska s hrotom PAC 121 T/M.....
120304	HG 12304	 Predlzena tryska PAC 121 T.....
120301	HG 12306	 Drziak trysky PAC 121 T/M.....(HOLMA Design)....
	HG 3111	 Deflektor.....(HOLMA Design)....
	HG 12309	 Distančna pruzina.....
120283	HG 12307	 Kontaktna krytka (na rucne rezanie).....(HOLMA Design)....
120326	HG 12308	 Kontaktna krytka (na strojne rezanie).....(HOLMA Design)....
020930	HG 1257	 Drziak trysky.....(HOLMA Design)....
Supravy na kruhove rezanie s prislusenstvom najdete na str.3		
Oznacenia "Hypertherm" ako aj "Max" su registrovane obchodne oznacenia firmy Hypertherm Inc. N.H. USA. V nasom katalogu su uvedene len z orientacnych dovodov. © Copyright 2009 by HOLMA® Switzerland. Vsetky prava vyhradene.		

Ref.cislo	Obj.cislo	Popis
Spotrebne diely vhodne pre Hypertherm® Powermax 900® (PAC125T/M)		
120576	HG 12311	 Rozvadzac vzduchu Vespele®
120573	HG 12300	 Elektroda Hafnium, long life..... (nahradi 020351)
120577	HG 12312	 Tryska 55 Amp PAC 125 T/M.....
120574	HG 12303	 Predlzena elektroda Hafnium..... (nahradi 020547)
120606 120578	HG 12313 HG 12314	 Tryska s hrotom 35 Amp PAC 125 T Predlzena tryska 55 Amp PAC 125 T
120600	HG 12315	 Drziak trysky PAC 125 T/M.....(HOLMA Design)....
120303	HG 3111/1	 Deflektor PAC 125 T/M..... (HOLMA Design).....
120601	HG 12307	 Kontakna krytka (na rucne rezanie)..... PAC 125 T.....(HOLMA Design).....
120602	HG 12308	 Kontakna krytka (na str. rezanie)..... PAC 125 M(HOLMA Design).....
<p>Supravy na kruhove rezanie s prislusenstvom najdete na str.3 Oznacenia "Hypertherm" ako aj "Max" su registrovane obchodne oznacenia firmy Hypertherm Inc. N.H. USA. V nasom katalogu su uvedene len z orientacnych dovodov. © Copyright 2009 by HOLMA® Switzerland.Vsetky prava vyhradene.</p>		

Ref.cislo	Obj.cislo	Popis
Spotrebne diely vhodne pre Hypertherm® Powermax 1000/1100/1250/1650®, T60/T60M®, RT60/RT60M®, T80/T80M®, RT80/RT80M®, T100/T100M®		
120925	HG 12350	 Rozvadzac vzduchu Vespel® (40-80A).....
120926	HG 12351	 Elektroda Hafnium (40-80A).....
120932 120931 120927	HG 12355 HG 12356 HG 12357	 Tryska 40A Tryska 60A Tryska 80A
220329	HG 12358	 FineCut tryska chrom T60/T80/T100.....
220006	HG 12359	 Predlzena tryska 40 Amp. Novell!
220007 120980	HG 12349 HG 12348	 Predlzena tryska 60 Amp. Novell! Predlzena tryska 80 Amp.
120928	HG 12352	 Drziak trysky (40-80A).....
120929	HG 12353	 Kontaktna krytka na trysku (ruc.rezanie 40-80A)..... (HOLMA Design)
120930	HG 12354	 Kontaktna krytka na trysku (stroj.rezanie 40-80A)..... (HOLMA Design)
220051	HG 12360	 Rozvadzac vzduchu Vespel® (100A).....
220037	HG 12361	 Elektroda Hafnium (100A).....
220011	HG 12365	 Tryska 100A
220048	HG 12362	 Drziak trysky (100A).....
220065	HG 12363	 Kontaktna krytka na trysku (ruc.rezanie 100A)..... (HOLMA Design)
220047	HG 12364	 Kontaktna krytka na trysku (stroj.rezanie 100A) (HOLMA Design)

Spotrebne diely vhodné pre
Hypertherm® MAX® 80 / 100 (PAC 130)

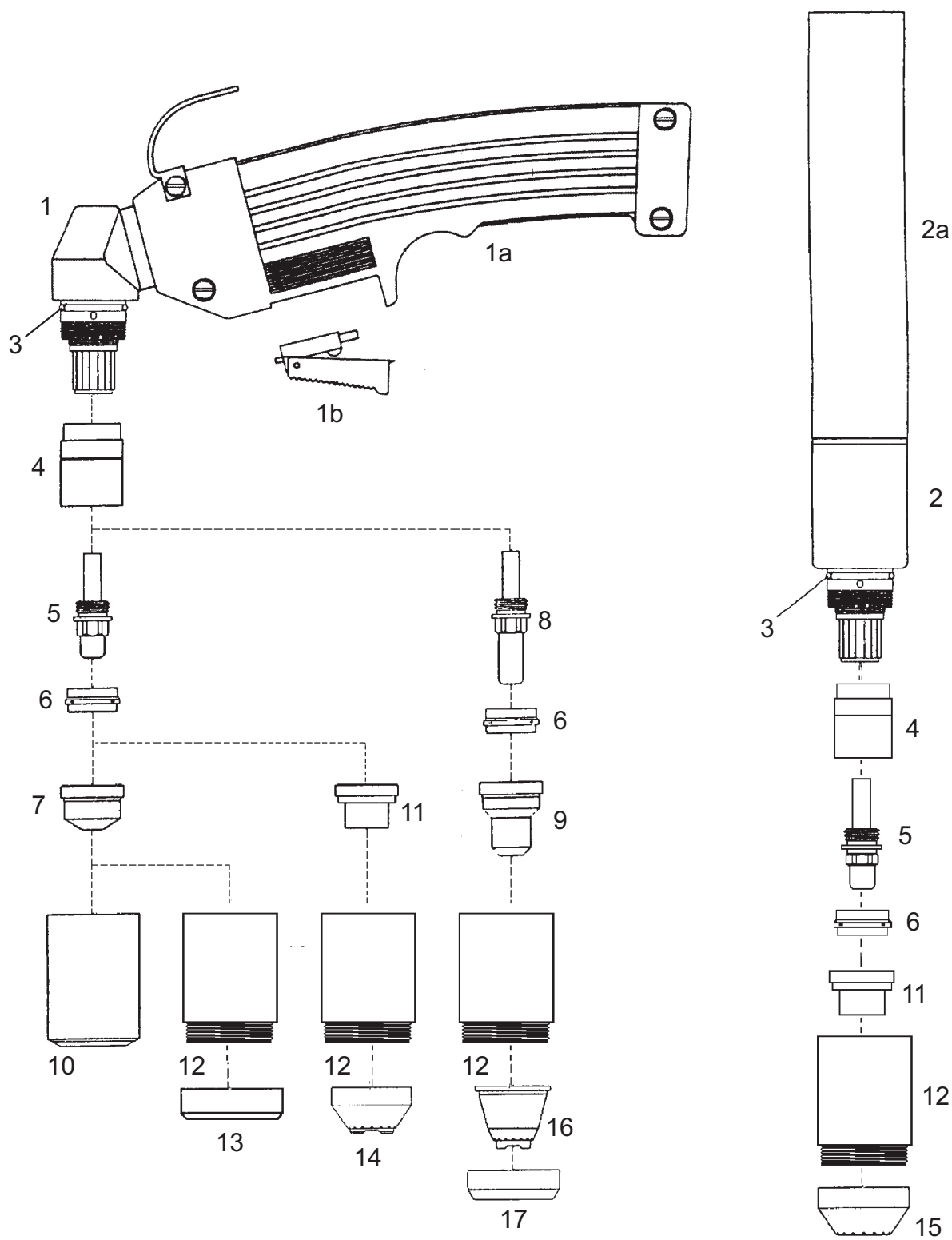









Oznacenia "HYPERTHERM" ako aj "MAX" su registrovane obchodne značky firmy Hypertherm Inc. N. H. USA. V nasom katalogu su uvedene len z orientacnych dovodov.

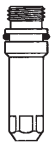



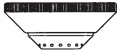

C.	Ref.cislo	Obj.cislo	Popis
	059076	HG 1245	Rucny horak komplet 25' - 7,5 m (1/2 - 20).....
	059077	HG 1246	Rucny horak komplet 50' - 15,0 m (1/2 - 20).....
	059008	HG 1247	Strojny horak komplet 25' - 7,5 m (1/2 - 20 s izolovanim kablom).....
	059009	HG 1248	Strojny horak komplet 50' - 15,0 m (1/2 - 20 s izolovanim kablom).....
		HG 1258	Kabel 25' - 7,5 m (1/2 - 20) na rucny horak.....
		HG 1259	Kabel 50' - 15,0 m (1/2 - 20) na rucny horak.....
		HG 1261	Kabel 25' - 7,5 m (1/2 - 20) izolovany, na str.horak.....
		HG 1262	Kabel 50' - 15,0 m (1/2 - 20) izolovany na str. horak.....
1	020189	HG 1242	Telo rucneho horaka s rukovätou a so spinacom.....
1a		HG 1026/5	Rukovät so spinacom.....
1b		HG 1026/6	Spinac.....
2	020201	HG 1243	Telo strojneho horaka.....
2a	020245	HG 3009	Dopravna trubica.....
3	026018	HG 2648	O - kruzok.....
4		HG 1043V	Vlozka - VESPEL®.....
5	120433	HG 1230	Elektroda Hafnium, long life (stare ref.cislo- 020191).....
6	020194	HG 1231	Rozvadzac vzduchu VESPEL®.....
7	020203	HG 1232	Tryska Ø 1,0 mm -.038 40 Amp.....
	020345	HG 1233	Tryska Ø 1,3 mm -.052 80 Amp.....
	020195	HG 1234	Tryska Ø 1,5 mm -.059 100 Amp.....
	020705	HG 1254	Tryska 100 Amp vhodna pre Hypertherm® MAX100D.....
8	020564	HG 1239	Predlzena elektroda, Hafnium.....
9		HG 12401	Predlzena tryska Ø 1,0 mm -.038
	020563	HG 1240	Predlzena tryska Ø 1,4 mm -.055
10	020184	HG 1235	Drziak trysky.....
11	020396	HG 1293	Kontaktna tryska Ø 1,0 mm -.038 40 Amp.....
	020397	HG 1241	Kontaktna tryska Ø 1,3 mm -.052 80 Amp.....
	020337	HG 1284	Kontaktna tryska Ø 1,5 mm -.059 100 Amp.....
12		HG 1237	Kontaktny drziak trysky HOLMA-Produkt.....
	020336	HG 1292	Kontaktny drziak trysky s VESPEL®-om HOLMA-Produkt.....
13	020333	HG 1253	Deflektor.....
14	020335	HG 1295	Kontaktna krytka na rucne rezanie, HOLMA-Design.....
15	020334	HG 1298	Kontaktna krytka na stroj. rezanie, HOLMA-Design.....
16		HG 1296	Kontaktna krytka na rucne rezanie (pre predlzenu trysku, obrazok c.11)..
17		HG 1297	Poistna matica.....

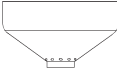
Oznacenia "Hypertherm" ako aj "Max" su registrovane obchodne znacky firmy Hypertherm Inc. N.H. USA.V nasom katalogu su uvedene len z orientacnych dôvodov.

© Copyright 2009 by HOLMA® Switzerland. Vsetky prava vyhradene.

Strana 27

Ref.cislo	Obj.cislo	Popis	
<p align="center">Spotrebne diely vhodne pre Hypertherm® Max 200®, PAC200T/E a HT 2000®</p>			
<p>120547 120667 120667 020415</p>	<p>HG 30134 HG 30035 HG 30035/B HG 30133</p>	 <p>Elektroda - kyslik 100A..... Elektroda - kyslik 200A (nahrada za 020664/020414/220021) Novell! Elektroda - kyslik 200A HOLMA BLUE LINE..... Elektroda - Ar/H 200A.....</p>	
<p>020689</p>	<p>HG 30074</p>	 <p>Tryska - .038, 40 Amp, vzduch.....</p>	
<p>020616 020611</p>	<p>HG 30062 HG 30058</p>	 <p>Tryska - .055, 100 Amp kyslik (MAX 200®)..... Tryska - .059, 100 Amp vzduch/dusik</p>	
<p>020605 020608 020690 020615</p>	<p>HG 30055 HG 30057 HG 30075 HG 30112</p>	 <p>Tryska - .082, 200 Amp kyslik..... Tryska - .086, 200 Amp vzduch/dusik..... Tryska - .055, 100 Amp kyslik (HT 2000®)..... Drazkovacia tryska, vzduch 200A</p>	
<p>020423</p>	<p>HG 30040</p>	 <p>Drziak trysky</p>	
<p>020424 020448</p>	<p>HG 30041 HG 30045</p>	 <p>Krytka - .086, 200 Amp, stroj. horak..... Krytka - .059, 100 Amp, stroj. horak.....</p>	
<hr/>			
<p align="center">Spotrebne diely vhodne pre Hypertherm® Hyspeed® HT 2000®</p>			
<p>220235</p>	<p>HG 30150</p>	 <p>Elektroda 200A O₂.....</p>	
<p>220237</p>	<p>HG 30155</p>	 <p>Tryska 200A O₂.....</p>	
<p>220238</p>	<p>HG 30158</p>	 <p>Drziak trysky 200A O₂.....</p>	
<p>220239</p>	<p>HG 30159</p>	 <p>Krytka 200A O₂.....</p>	
<p align="center">Oznacenia "Hypertherm" ako aj "Max" su registrovane obchodne znacky firmy Hypertherm Inc. N.H. USA.V nasom katalogu su uvedene len z orientacnych dovodov.</p>			
<p align="center">© Copyright 2009 by HOLMA® Switzerland. Vsetky prava vyhradene.</p>			

Ref.cislo	Obj.cislo	Popis	
Spotrebne diely vhodne pre Hypertherm® Max® 40CS, Max® 42, Max® 43 (PAC 121PT/M)			
020361	HG 1260	 Rozvadzac vzduchu VESPEL®	
120573	HG 12300	 Elektroda Hafnium, long life..... (Stare ref.cislo 020351)	
020350 020395	HG 1211 HG 1212	 Tryska Ø 0,96 - .038..... Tryska Ø 1,06 - .042.....	
020542	HG 1218	 Konicka tryska	
120574	HG 12303	 Predlzena elektroda Hafnium..... (Stare ref.cislo 020547)	
020546	HG 1214	 Predlzena tryska Ø 0,96 - .038	
020930	HG 1257	 Drziak trysky	