

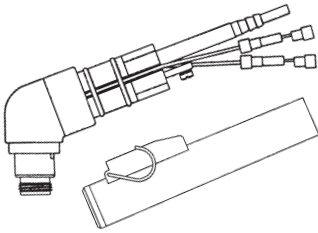











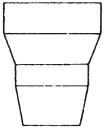
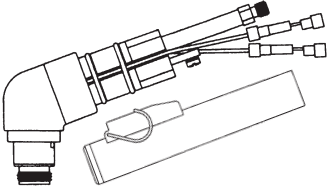



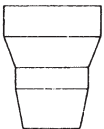
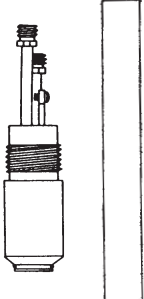

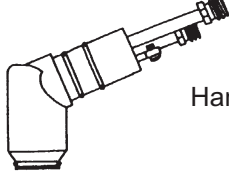
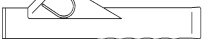





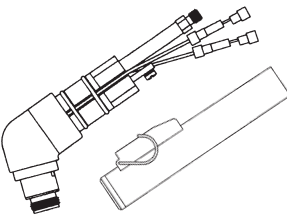



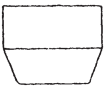
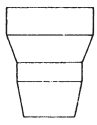

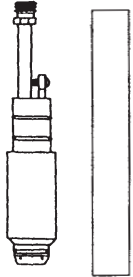
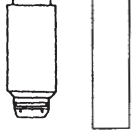
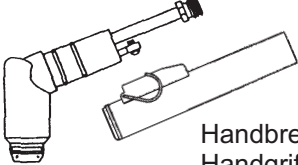





Ref.- Nr.	Bestell-Nr.	Artikelbezeichnung
Verschleissteile passend für Thermal Dynamics® PCH-10 Drag-Gun, Cougar 125		
	HG 14.386	Luft und Strom Kabel 6m.....
2-1020	HG 14.385	 Handbrenner komplett mit 6m Kabel.....
9-0016 9-0019E	HG 14.063 HG 14.065	
8-0533	HG 1221A	O-Ring für Griff.....
9-6006	HG 14.007	 Elektrode Hafnium.....
9-6007	HG 14.006	 Luftverteiler - Vespel®
9-6099	HG 14.064	 Düse - Luft.....
9-6003	HG 14.003	 Schutzkappe..... Das dazugehörige Kreisschneideset und Zubehör finden Sie auf der Seite 3.
Verschleissteile passend für Thermal Dynamics® PCH-25/38 PCH-26 Pak Master 38XL, Drag-Gun 38, Econopak 50		
2-0380	HG 14.387	Handbrenner 12,5' - 3,8 m (PCH-25/38).....
2-0381	HG 14.388	Handbrenner 25' - 7,5 m (PCH-25/38).....
4-6067	HG 14.389	Kabel 12,5' - 3,8 m Handbrenner (PCH-25/38).....
4-6068	HG 14.390	Kabel 25' - 7,5 m Handbrenner (PCH-25/38).....
2-3501	HG 14.391	Handbrenner 12,5' - 3,8 m (PCH-26).....
2-3511	HG 14.392	Handbrenner 25' - 7,5 m (PCH-26).....
4-6071	HG 14.067	Kabel 12,5' - 3,8 m Handbrenner (PCH-26).....
4-6072	HG 14.393	Kabel 25' - 7,5 m Handbrenner (PCH-26).....
9-5807 9-6282E	HG 14.028 HG 14.065	 Handbrennerkörper 70°..... Handgriff mit Mikroschalter.....
8-0533	HG 1221A	
9-6506	HG 14.023	 Elektrode Hafnium, verstärkt.....
9-6507	HG 14.024	 Luftverteiler, verstärkt.....
9-6501	HG 14.026	 Düse (drag cut), verstärkt.....
9-6003	HG 14.003	 Schutzkappe..... Das dazugehörige Kreisschneideset und Zubehör finden Sie auf der Seite 3.
© Copyright 2010 by HOLMA® Switzerland. Alle Rechte vorbehalten.		

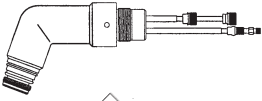
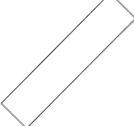

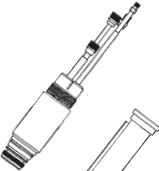
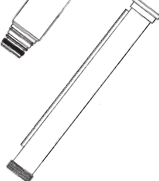

Ref.- Nr.	Bestell-Nr.	Artikelbezeichnung	
Verschleissteile passend für Thermal Dynamics® PCH/M- 52 Pak-5XR*, Pak-6XR*, Pak-7XR, Pak-8XR, Pak-10-XR, Pak-625XR* Pak-750-XR*, Pak-1000XR, Pak-1250-XR *=Dual Gas			
2-2936 2-2937 2-2938 2-2939	HG 1446 HG 1447 HG 1448 HG 1449	Handbrenner 25' - 7,5 m..... Handbrenner 50' - 15,0 m..... Maschinenbrenner 25' - 7,5 m..... Maschinenbrenner 50' - 15,0 m.....	
4-5034 4-5035 4-5036 4-5037	HG 1463 HG 1464 HG 14.131 HG 14.132	 Kabel 25' - 7,5 m Handbrenner..... Kabel 50' - 15,0 m Handbrenner..... Kabel 25' - 7,5 m Maschinenbrenner..... Kabel 50' - 15,0 m Maschinenbrenner.....	
9-5643 9-7833	HG 1429 HG 14.133	 Maschinenbrennerkörper 180° Führungsrohr.....	
8-5525 8-0536	HG 1044 HG 14.397	 O-Ring (Schutzkappe)..... O-Ring (Griff).....	
9-5642	HG 1428	 Handbrennerkörper 70°	
9-5644E	HG 14.319	 Handgriff komplett mit Mikroschalter.....	
8-3331 9-5619	HG 1410 HG 1410/1	 Elektrode Luft, long life..... Elektrode Hafnium, vernickelt.....	
9-5702 9-5618 9-5707 9-5782 9-5708 8-5129 9-5709 9-5710 9-5713	HG 1411 HG 1412 HG 1414 HG 1420 HG 1415 HG 1427 HG 1413 HG 1416 HG 1417	 Düse Ø 0,90 mm - .035 35 Amp..... Düse Ø 1,10 mm - .043 45-55 Amp..... Düse Ø 1,20 mm - .047 60-70 Amp..... Düse Ø 1,32 mm - .052 80 Amp..... Düse Ø 1,50 mm - .059 105 Amp..... Fugenhobeldüse..... Fugenhobeldüse Ø 1,99 mm - .078 70 Amp..... Fugenhobeldüse Ø 2,36 mm - .093 105 Amp..... Fugenhobeldüse Ø 2,87 mm - .113 105 Amp.....	
9-5617 9-5781 9-5799	HG 1418 HG 1426 HG 1498	 Schutzkappe, Keramik..... Schutzkappe, Phenolic..... Schutzkappe, Metall.....	
9-5780	HG 1421	 Kronenschutzkappe, Metall..... (nur in Verwendung mit HG 1426)	
9-5694	HG 1419	 Kronenschutzkappe, Keramik.....	
Das zugehörige Kreisschneideset und Zubehör finden Sie auf der Seite 3.			

Ref.- Nr.	Bestell-Nr.	Artikelbezeichnung	
Verschleissteile passend für Thermal Dynamics® PCH/M-28 und PCH/M-35 Pak Master 50XL, Pak Master 50, Stak Pak			
2-5801 2-5802 4-2995 4-2996	HG 14.029 HG 14.030 HG 14.402 HG 14.403	Handbrenner 25' - 7,5 m (PCH/M-28)..... Handbrenner 50' - 15,0 m (PCH/M-28)..... Kabel 25' - 7,5 m Handbrenner (PCH/M-28)..... Kabel 50' - 15 m Handbrenner (PCH/M-28).....	
8-0533 9-5807 9-6291E/8-4305E	HG 1221A HG 14.028 HG 14.065	 O-Ring (für Handgriff)..... Handbrennerkörper 70°..... Handgriff mit Mikroschalter.....	
9-6006 9-6506	HG 14.007 HG 14.023	 Elektrode Hafnium (nur PCH/M - 35)..... Elektrode Hafnium, verstärkt.....	
9-6007 9-6507	HG 14.006 HG 14.024	 Luftverteiler (nur PCH/M - 35)..... Luftverteiler, verstärkt.....	
9-6000 9-6500 9-6002	HG 14.000 HG 14.025 HG 14.002	 Düse Ø 0,78 mm - .030, 35A Luft (nur PCH/M - 35)..... Düse Ø 0,78 mm, verstärkt..... Düse, Fugenhobeln (nur PCH/M - 35).....	
9-6001 9-6501	HG 14.001 HG 14.026	 Düse (drag cut - Luft) (nur PCH/M - 35)..... Düse (drag cut - Luft), verstärkt.....	
9-6503	HG 14.027	 Schutzkappe (verstärkt)..... (Nur in Verwendung mit HG14.003)	
9-6003	HG 14.003	 Schutzkappe Std.....	
9-6004	HG 14.004	 Kronenschutzkappe..... (Nur in Verwendung mit HG14.003)	
Das dazugehörige Kreisschneideset und Zubehör finden Sie auf der Seite 3.			
© Copyright 2010 by HOLMA® Switzerland. Alle Rechte vorbehalten.			

HOLMA® ist in keiner Weise mit Thermal Dynamics® verbunden. Die zum Verkauf angebotenen Teile sind keine original Thermal Dynamics® Teile, aber sie sind hergestellt von und für HOLMA®. Angaben zu Thermal Dynamics® Maschinen, Brennern und Nummern dienen nur zu Ihrer Orientierung.

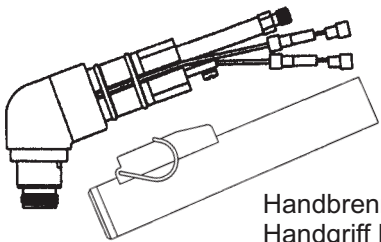
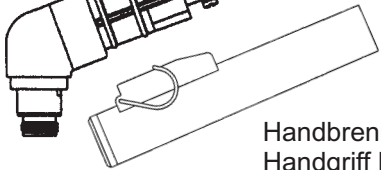
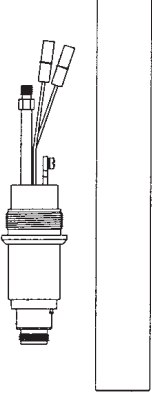
Ref.-Nr.	Bestell-Nr.	Artikelbezeichnung	
Verschleissteile passend für Thermal Dynamics® PCH/M-51			
4Xi, 6Xi, Pak-3XR, Pak-6XR, Pak-7XR, Pak-5XT, Pak-625XR, Pak-750XR			
2-2860 2-2861 2-2864 2-2865 4-5030 4-5031 4-5032 4-5033	HG 1438 HG 1439 HG 14.127 HG 14.128 HG 1442 HG 1443 HG 14.129 HG 14.130	 <p> Handbrenner 25' - 7,5 m, 9/16-Anschluss..... Handbrenner 50' - 15,0 m, 9/16-Anschluss..... Maschinenbrenner 25' - 7,5 m..... Maschinenbrenner 50' - 15 m..... Kabel 25'- 7,5 m für Handbrenner..... Kabel 50'-15,0 m für Handbrenner..... Kabel 25'- 7,5 m für Maschinenbrenner..... Kabel 50'-15,0 m für Maschinenbrenner..... </p>	
9-5634 9-5637E	HG 1408 HG 14.053	 <p> Maschinenbrennerkörper 180°..... Führungsrohr..... </p>	
8-5525 8-0533	HG 1044 HG 1221A	<p> O-Ring (für Schutzkappe)..... O-Ring (für Griff)..... </p>	
9-5635 9-5636E	HG 1407 HG 14.065	 <p> Handbrennerkörper 70°..... Handgriff kpl. mit Mikroschalter..... </p>	
9-5633 9-5720	HG 1400 HG 1405	 <p> Elektrode Hafnium..... Elektrode Hafnium (4x1)..... </p>	
9-5718 9-5631 8-3321 9-5724	HG 1425 HG 1401 HG 14.401 HG 1404	 <p> Düse Ø 0,96 - .038 10 - 40 Amp..... Düse Ø 1,10 - .043 10 - 60 Amp..... Düse Ø 1,20 - .047 - 65 Amp..... Fugenhobeldüse Ø 2,00 - .078..... </p>	
9-5630 8-2159	HG 1402 HG 1423	 <p> Keramikschutzkappe..... Schutzkappe, Phenolic Std..... </p>	
9-5779	HG 1424	 <p> Kronenschutzkappe, Metall..... (Nur in Verwendung mit HG1423) </p>	
8-5526	HG 1403	 <p> Kronenschutzkappe, Keramik..... </p>	
Das dazugehörige Kreisschneideset und Zubehör finden Sie auf der Seite 4.			
Seite 8 © Copyright 2010 by HOLMA® Switzerland. Alle Rechte vorbehalten.			

Ref.-Nr.	Bestell-Nr.	Artikelbezeichnung	
Verschleissteile passend für Thermal Dynamics® Maximizer 300			
Merlin 1000, Merlin 3000, Merlin 6000, Merlin 6000 GST			
9-6457 9-6459 8-0538	HG 14.276 HG 14.277 HG 14.398	 Handbrennerkörper 70° Handbrennerkörper 90° O-Ring.....	
9-6769	HG 14.278	 Montagerohr.....	
9-6767	HG 14.279	 Adapter.....	
9-6410	HG 14.189	 Maschinenbrennerkörper 180°	
7-3207 8-4204	HG 14.152 HG 14.102	 Führungsrohr (für Merlin 1000)..... Endkappe (für Merlin 1000).....	
8-2158	HG 14.151	 Adapter (für Merlin 1000).....	
20-1010 20-1015 20-1016 20-1017 20-1018 20-1021 20-1023 20-1025	HG 14.282 HG 14.283 HG 14.284 HG 14.285 HG 14.261 HG 14.286 HG 14.287 HG 14.288	 Elektrode O2 100-225A (für 3000, 6000 & GST).... Elektrode O2 100A (für 3000 & 6000)..... Elektrode O2 150A (für 1000, 3000 & 6000)..... Elektrode O2 225A (für 3000 & 6000)..... Elektrode Luft/O2 50-225A (für alle)..... Elektrode Luft/O2 300A (für 3000, 6000 & GST).... Elektrode N2 50-300A (für alle)..... Elektrode Ar/H2 100-300A (für alle).....	
20-0008 20-1009	HG 14.306 HG 14.291	 Luftverteiler 50-225 Amp (für alle)..... Luftverteiler 300 Amp (für 3000, 6000 & GST).....	
20-1030 20-1031 20-1032 20-1033 20-1034	HG 14.292 HG 14.293 HG 14.294 HG 14.295 HG 14.296	 Düse 50 Amp O2/N2/Air (für alle)..... Düse 100 Amp O2/N2/Air (für alle)..... Düse 150 Amp (für 3000, 6000 & GST)..... Düse 225 Amp (für 3000, 6000 & GST)..... Düse 300 Amp (für alle).....	
20-1002 20-1029	HG 14.308 HG 14.298	 Schutzkappe (für alle)..... Schutzkappe Unterwasser (für 1000, 6000 & GST).	
20-1003 20-1004 20-1005 20-1006 20-1007 20-1028	HG 14.299 HG 14.300 HG 14.301 HG 14.302 HG 14.303 HG 14.304	 Endkappe 50 Amp (für alle)..... Endkappe 100-225 Amp (für alle)..... Endkappe 300Amp (für 3000, 6000 & GST)..... Endkappe Unterwasser 100-300 Amp (6000, GST). Endkappe nicht leitend (für 3000, 6000 & GST)..... Endkappe Unterwasser (für 6000).....	
Square Cut, 50A, O2-O2 Verschleissteile:			
20-1050 20-0008 20-1051 20-1002 20-1052	HG 14.305 HG 14.306 HG 14.307 HG 14.308 HG 14.309	Elektrode O2..... Luftverteiler 50-225 Amp..... Düse 50 Amp..... Schutzkappe..... Schutzkappenendkappe 50 Amp.....	

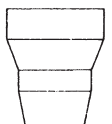
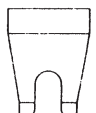
Ref.-Nr.	Bestell-Nr.	Artikelbezeichnung	
Verschleissteile passend für Thermal Dynamics® PCH/M-40 Pak Master 50XL Plus			
2-5035 2-5036 2-5039 2-5040 4-0815 4-0816 4-2897 4-2898	HG 14.156 HG 14.157 HG 14.158 HG 14.159 HG 14.068 HG 14.069 HG 14.160 HG 14.161	Handbrenner 25' - 7,5 m..... Handbrenner 50' - 15 m..... Maschinenbrenner 25' - 7,5 m..... Maschinenbrenner 50' - 15 m..... Kabel 25' - 7,5 m Handbrenner..... Kabel 50' - 15 m Handbrenner..... Kabel 25' - 7,5 m Maschinenbrenner..... Kabel 50' - 15 m Maschinenbrenner.....	
8-0533	HG 1221A	 O-Ring (für Handgriff)	
9-8055 9-8059	HG 14.162 HG 14.065	 Handbrennerkörper 70° Handgriff kpl. mit Mikroschalter.....	
9-8053 9-7833	HG 14.163 HG 14.164	 Maschinenbrennerkörper 180° Führungsrohr.....	
9-6506	HG 14.023	 Elektrode Hafnium, verstärkt.....	
9-6507	HG 14.024	 Luftverteiler - Vespel®	
9-6500	HG 14.025	 Düse verstärkt.....	
9-6501 9-6502	HG 14.026 HG 14.165	 Düse verstärkt (drag cut)..... Fugenhobeldüse.....	
9-6003	HG 14.003	 Schutzkappe Std.....	
9-6004	HG 14.004	 Kronenschutzkappe..... Das dazugehörige Kreisschneideset und Zubehör finden Sie auf der Seite 3.	

Verschleissteile passend für Thermal Dynamics® PCH/M-75, - 76 und - 100XL

Pak Master 75, Pak Master 75XL, 625XR, Cut Master 80XL, Econopak 100, Pak Master 100XL

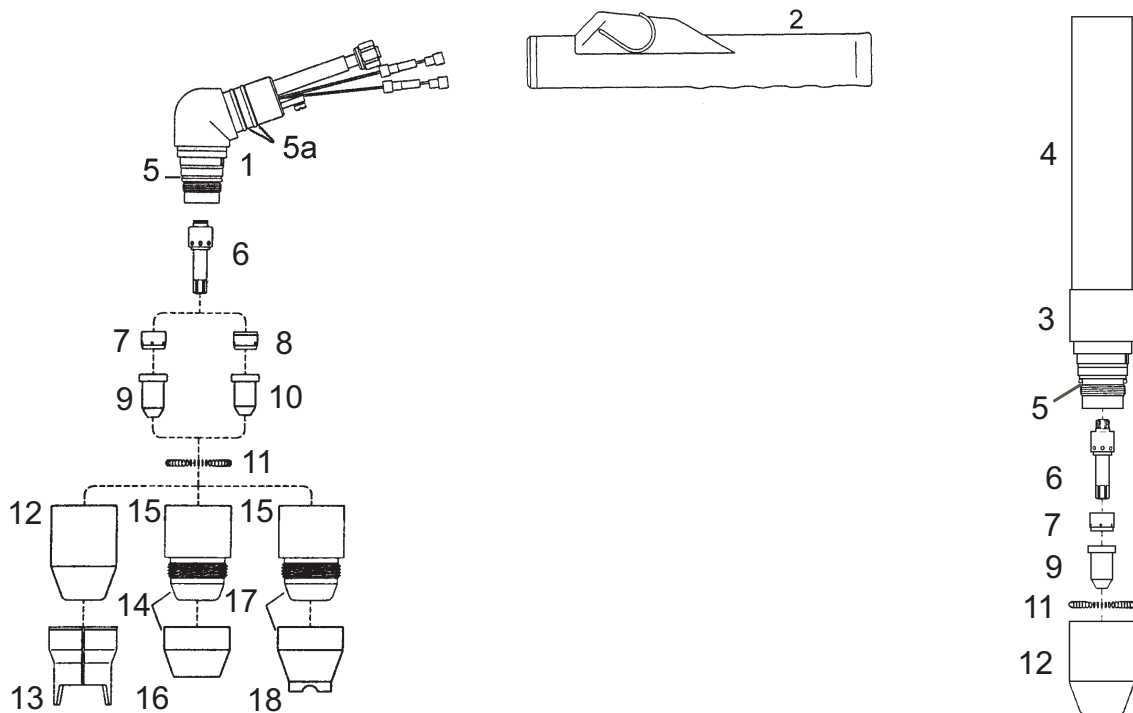

Nr.	Ref.- Nr.	Bestell-Nr.	Artikelbezeichnung
	2-7801	HG 14.031	Handbrenner 25' - 7,5 m (zusätz. Ref.Nr. 2-7811, 2-0801).....
	2-7802	HG 14.032	Handbrenner 50' - 15,0 m (zusätz. Ref.Nr. 2-7812, 2-0802).....
	2-7805	HG 14.050	Maschinenbrenner 25' - 7,5 m (zusätz. Ref.Nr. 2-0805).....
	2-7806	HG 14.051	Maschinenbrenner 50' - 15,0 m (zusätz. Ref.Nr. 2-0806).....
	4-7801	HG 14.047	Kabel 25' - 7,5 m Handbrenner (zusätz. Ref.Nr. 4-0810, 4-7611).....
	4-7802	HG 14.048	Kabel 50' - 15,0 m Handbrenner (zusätz. Ref.Nr. 4-0811, 4-7612).....
	4-7803	HG 14.096	Kabel 25' - 7,5 m Maschinenbrenner (zusätz. Ref.Nr. 4-0812).....
	4-7804	HG 14.097	Kabel 50' - 15,0 m Maschinenbrenner (zusätz. Ref.Nr. 4-0813).....
1	8-7510	HG 14.033	Handbrennerkörper 70°.....
2	9-5636E	HG 14.034	Handgriff kpl. mit Mikroschalter.....
3	8-7512	HG 14.052	Maschinenbrennerkörper 180° (nicht PCH/M - 76).....
4	9-5637E	HG 14.053	Führungsrohr für Maschinenbrenner (nicht PCH/M - 76).....
5	8-0532	HG 1221	O-Ring (Schutzkappe).....
5a	8-0533	HG 1221A	O-Ring (Handgriff).....
6	8-7502	HG 14.036	Elektrode Hafnium.....
7	8-7501	HG 14.037	Luftverteiler für Schneiddüsen.....
8	8-7508	HG 14.038	Luftverteiler für Fugenhobeldüsen.....
9	8-7503	HG 14.039	Düse Ø 0,99 - .039 35 Amp.....
	8-7504	HG 14.040	Düse Ø 1,17 - .046 55 Amp (nicht PCH/M - 76).....
	8-7505	HG 14.041	Düse Ø 1,32 - .052 60-70 Amp (nicht PCH/M - 75).....
10	8-7506	HG 14.042	Fugenhobeldüse Ø 1,86 - .073.....
11	9-7501E	HG 14.043	Feder.....
12	8-7500	HG 14.044	Schutzkappe.....
13	8-7575	HG 14.049	Abstandsstück mit 2 Spitzen.....
14	8-7496	HG 14.174	Schutzkappe kpl. Maximum life.....
15	8-7498	HG 14.045	Kontaktschutzkappe.....
16	8-7497	HG 14.098	Hitzeschild (Kupfer).....
17	8-7507	HG 14.175	Kronenschutzkappe Set.....
18	8-7499	HG 14.046	Kronenschutzkappe (Kupfer).....

Das dazugehörige Kreisschneideset und Zubehör finden Sie auf der Seite 3.

© Copyright 2010 by HOLMA® Switzerland. Alle Rechte vorbehalten.

Seite 11