

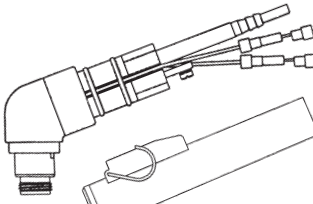











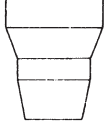
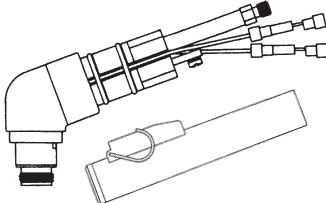



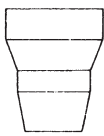
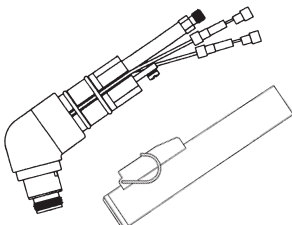





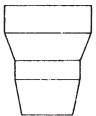

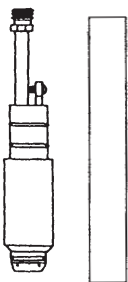
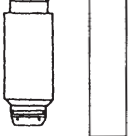
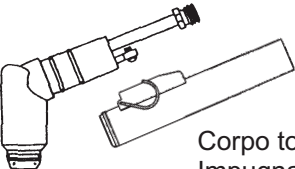





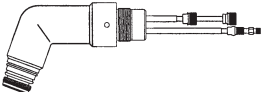
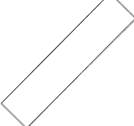

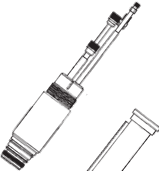



Codice	N° Articolo	Descrizione
<b>Ricambi compatibili con Thermal Dynamics® PCH-10 Drag-Gun, Cougar 125</b>		
	HG 14.386	Fascio cavi - elettrico e aria - 6m.....
2-1020	HG 14.385	Torcia manuale completa con cavo 6m. 
9-0016 9-0019E	HG 14.063 HG 14.065	Corpo torcia manuale 70° ..... Impugnatura con pulsante.....
8-0533	HG 1221A	O-ring impugnatura.....
9-6006	HG 14.007	Elettrodo Hafnium..... 
9-6007	HG 14.006	Diffusore Aria - Vespel® ..... 
9-6099	HG 14.064	Ugello - Aria..... 
9-6003	HG 14.003	Protezione..... 
Per il relativo kit compasso per torcia e accessori vedere pagina 3.		
<b>Ricambi compatibili con Thermal Dynamics® PCH-25/38 PCH-26 Pak Master 38XL, Drag-Gun 38, Econopak 50</b>		
2-0380	HG 14.387	Torcia manuale 12.5' - 3,8 m (PCH-25/38).....
2-0381	HG 14.388	Torcia manuale 25' - 7,5 m (PCH-25/38).....
4-6067	HG 14.389	Cavo torcia manuale 12,5' - 3,8 m (PCH-25/38).....
4-6068	HG 14.390	Cavo torcia manuale 25' - 7,5 m (PCH-25/38).....
2-3501	HG 14.391	Torcia manuale 12.5' - 3,8 m (PCH-26).....
2-3511	HG 14.392	Torcia manuale 25' - 7,5 m (PCH-26).....
4-6071	HG 14.067	Cavo torcia manuale 12,5' - 3,8 m (PCH-26).....
4-6072	HG 14.393	Cavo torcia manuale 25' - 7,5 m (PCH-26).....
9-5807 9-6282E	HG 14.028 HG 14.065	Corpo torcia manuale 70° ..... Impugnatura con pulsante..... 
8-0533	HG 1221A	O-ring impugnatura.....
9-6506	HG 14.023	Elettrodo Hafnium, rinforzato..... 
9-6507	HG 14.024	Diffusore Aria, rinforzato..... 
9-6501	HG 14.026	Ugello (drag cut), rinforzato..... 
9-6003	HG 14.003	Protezione..... 
Per il relativo kit compasso per torcia e accessori vedere pagina 3.		

Codice	N° Articolo	Descrizione
<b>Ricambi compatibili con            Thermal Dynamics® PCH/M- 52</b> <b>Pak-5XR*, Pak-6XR*, Pak-7XR, Pak-8XR, Pak-10-XR, Pak-625XR*</b> <b>Pak-750-XR*, Pak-1000XR, Pak-1250-XR      *=Dual Gas</b>		
2-2936	HG 1446	Torcia manuale 25' - 7,5 m.....
2-2937	HG 1447	Torcia manuale 50' - 15,0 m.....
2-2938	HG 1448	Torcia automatica 25' - 7,5 m.....
2-2939	HG 1449	Torcia automatica 50' - 15,0 m.....
4-5034	HG 1463	Fascio cavi torcia manuale 25' - 7,5 m .....
4-5035	HG 1464	Fascio cavi torcia manuale 50' - 15,0 m .....
4-5036	HG 14.131	Fascio cavi torcia automatica 25' - 7,5 m.....
4-5037	HG 14.132	Fascio cavi torcia automatica 50' - 15,0 m.....
9-5643	HG 1429	Corpo torcia automatica 180° .....
9-7833	HG 14.133	Tubo di posizionamento.....
8-5525	HG 1044	O-ring (Protezione).....
8-0536	HG 14.397	O-ring (Impugnatura).....
9-5642	HG 1428	Corpo torcia manuale 70°.....
9-5644E	HG 14.319	Impugnatura completa con pulsante.....
8-3331	HG 1410	Elettrodo Aria, long life.....
9-5619	HG 1410/1	Elettrodo Hafnium, nichelato.....
9-5702	HG 1411	Ugello Ø 0,90 mm - .035 35 Amp.....
9-5618	HG 1412	Ugello Ø 1,10 mm - .043 45-55 Amp.....
9-5707	HG 1414	Ugello Ø 1,20 mm - .047 60-70 Amp.....
9-5782	HG 1420	Ugello Ø 1,32 mm - .052 80 Amp.....
9-5708	HG 1415	Ugello Ø 1,50 mm - .059 105 Amp.....
8-5129	HG 1427	Ugello per scricatura.....
9-5709	HG 1413	Ugello per scricatura Ø 1,99 mm - .078 70 A.....
9-5710	HG 1416	Ugello per scricatura Ø 2,36 mm - .093 105 A.....
9-5713	HG 1417	Ugello per scricatura Ø 2,87 mm - .113 105 A.....
9-5617	HG 1418	Protezione, Ceramica.....
9-5781	HG 1426	Protezione, Fenolica.....
9-5799	HG 1498	Protezione, Metallo.....
9-5780	HG 1421	Distanziale in metallo - Corona..... (Per uso con HG 1426)
9-5694	HG 1419	Protezione ceramica - Corona.....
Per il relativo kit compasso per torcia e accessori vedere pagina 3.		

Codice	N° Articolo	Descrizione
<b>Ricambi compatibili con            Thermal Dynamics® PCH/M-28 e PCH/M-35            Pak Master 50XL, Pak Master 50, Stak Pak</b>		
2-5801 2-5802 4-2995 4-2996	HG 14.029 HG 14.030 HG 14.402 HG 14.403	Torcia manuale 25' - 7,5 m (PCH/M-28)..... Torcia manuale 50' - 15,0 m (PCH/M-28)..... Fascio cavi 25' - 7,5 m torcia manuale (PCH/M-28). Fascio cavi 50' - 15 m torcia manuale (PCH/M-28).
8-0533 9-5807 9-6291E/8-4305E	HG 1221A HG 14.028 HG 14.065	 O-ring (per impugnatura)..... Corpo torcia manuale 70°..... Impugnatura con pulsante.....
9-6006 9-6506	HG 14.007 HG 14.023	 Elettrodo Hafnium (solo PCH/M - 35)..... Elettrodo Hafnium, rinforzato.....
9-6007 9-6507	HG 14.006 HG 14.024	 Diffusore Aria (solo PCH/M - 35)..... Diffusore Aria, rinforzato.....
9-6000 9-6500 9-6002	HG 14.000 HG 14.025 HG 14.002	 Ugello Ø 0,78 mm-.030, 35A Aria (solo PCH/M-35). Ugello Ø 0,78 mm, rinforzato..... Ugello, scricatura (solo PCH/M - 35).....
9-6001 9-6501	HG 14.001 HG 14.026	 Ugello (drag cut - Aria) (solo PCH/M - 35)..... Ugello (drag cut - Aria), rinforzato.....
9-6503	HG 14.027	 Protezione (rinforzato)..... (per uso con HG14.003)
9-6003	HG 14.003	 Protezione Std.....
9-6004	HG 14.004	 Protezione a corona..... (Per uso con HG14.003)
Per il relativo kit compasso per torcia e accessori vedere pagina 3		
© Copyright 2009 by HOLMA® Switzerland. Tutti i diritti riservati.		

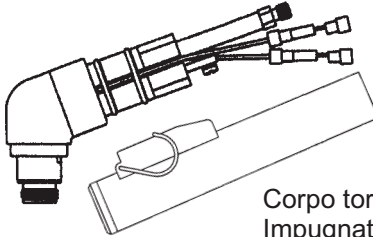
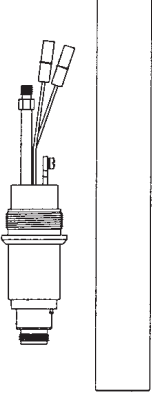
Codice	N° Articolo	Descrizione	
<b>Ricambi compatibili con Thermal Dynamics® PCH/M-51</b>			
<b>4Xi, 6Xi, Pak-3XR, Pak-6XR, Pak-7XR, Pak-5XT, Pak-625XR, Pak-750XR</b>			
2-2860 2-2861 2-2864 2-2865 4-5030 4-5031 4-5032 4-5033	HG 1438 HG 1439 HG 14.127 HG 14.128 HG 1442 HG 1443 HG 14.129 HG 14.130	 <p>Torcia manuale 25' - 7,5 m, - raccordo 9/16.....</p> <p>Torcia manuale 50' - 15,0 m, - raccordo 9/16.....</p> <p>Torcia automatica 25' - 7,5 m.....</p> <p>Torcia automatica 50' - 15 m.....</p> <p>Fascio cavi 25'- 7,5 m per torcia manuale .....</p> <p>Fascio cavi 50'-15,0 m per torcia manuale .....</p> <p>Fascio cavi 25'- 7,5 m per torcia automatica.....</p> <p>Fascio cavi 50'-15,0 m per torcia automatica.....</p>	
9-5634 9-5637E	HG 1408 HG 14.053	 <p>Corpo torcia automatica 180°.....</p> <p>Tube di posizionamento.....</p>	
8-5525 8-0533	HG 1044 HG 1221A	<p>O-ring (per protezione).....</p> <p>O-ring (per impugnatura).....</p>	
9-5635 9-5636E	HG 1407 HG 14.065	 <p>Corpo torcia manuale 70° .....</p> <p>Impugnatura completa con pulsante.....</p>	
9-5633 9-5720	HG 1400 HG 1405	 <p>Elettrodo Hafnium.....</p> <p>Elettrodo Hafnium (4x1).....</p>	
9-5718 9-5631 8-3321 9-5724	HG 1425 HG 1401 HG 14.401 HG 1404	 <p>Ugello Ø 0,96 - .038 10 - 40 A.....</p> <p>Ugello Ø 1,10 - .043 10 - 60 A.....</p> <p>Ugello Ø 1,20 - .047 - 65 A.....</p> <p>Ugello per scriccatura Ø 2,00 - .078.....</p>	
9-5630 8-2159	HG 1402 HG 1423	 <p>Protezione ceramica.....</p> <p>Protezione, fenolica Std.....</p>	
9-5779	HG 1424	 <p>Protezione a corona, metallo.....</p> <p>(per uso con HG1423)</p>	
8-5526	HG 1403	 <p>Protezione a corona, ceramica.....</p>	
Per il relativo kit compasso per torcia e accessori vedere pagina 4.			
<b>Pagina 8</b>			
<b>© Copyright 2009 by HOLMA® Switzerland. Tutti i diritti riservati.</b>			

Codice	N° Articolo	Descrizione	
<b>Ricambi compatibili con Thermal Dynamics® Maximizer 300</b> <b>Merlin 1000, Merlin 3000, Merlin 6000, Merlin 6000 GST</b>			
9-6457	HG 14.276	 Corpo torcia manuale 70°..... Corpo torcia manuale 90°..... O-ring.....	
9-6459	HG 14.277		
8-0538	HG 14.398		
9-6769	HG 14.278	 Supporto.....	
9-6767	HG 14.279	 Adattatore.....	
9-6410	HG 14.189	 Corpo torcia automatica 180°.....	
7-3207	HG 14.152	 Tubo di posizionamento (per Merlin 1000)..... Boccola protezione cavo (per Merlin 1000).....	
8-4204	HG 14.102		
8-2158	HG 14.151	 Adattatore (per Merlin 1000).....	
20-1010	HG 14.282	 Elettrodo O2 100-225A (per 3000, 6000 & GST)..... Elettrodo O2 100A (per 3000 & 6000)..... Elettrodo O2 150A (per 1000, 3000 & 6000)..... Elettrodo O2 225A (per 3000 & 6000)..... Elettrodo Aria/O2 50-225A (per tutte)..... Elettrodo Aria/O2 300A (per 3000, 6000 & GST)..... Elettrodo N2 50-300A (per tutte)..... Elettrodo Ar/H2 100-300A (per tutte).....	
20-1015	HG 14.283		
20-1016	HG 14.284		
20-1017	HG 14.285		
20-1018	HG 14.261		
20-1021	HG 14.286		
20-1023	HG 14.287		
20-1025	HG 14.288		
20-0008	HG 14.306		 Diffusore Aria 50-225 A (per tutte)..... Diffusore Aria 300 A (per 3000, 6000 & GST).....
20-1009	HG 14.291		
20-1030	HG 14.292	 Ugello 50 A O2/N2/Air (per tutte)..... Ugello 100 A O2/N2/Air (per tutte)..... Ugello 150 A (per 3000, 6000 & GST)..... Ugello 225 A (per 3000, 6000 & GST)..... Ugello 300 A (per tutte).....	
20-1031	HG 14.293		
20-1032	HG 14.294		
20-1033	HG 14.295		
20-1034	HG 14.296		
20-1002	HG 14.308	 Protezione (per tutte)..... Protezione Underwater (per 1000, 6000 & GST).....	
20-1029	HG 14.298		
20-1003	HG 14.299	 Boccola esterna 50 A (per tutte)..... Boccola esterna 100-225 A (per tutte)..... Boccola esterna 300A (per 3000, 6000 & GST)..... Boccola esterna Underwater 100-300 A (6000, GST).. Boccola esterna isolata (per 3000, 6000 & GST)..... Boccola esterna Underwater (per 6000).....	
20-1004	HG 14.300		
20-1005	HG 14.301		
20-1006	HG 14.302		
20-1007	HG 14.303		
20-1028	HG 14.304		
<b>Square Cut, 50A, O2-O2 ricambi compatibili:</b>			
20-1050	HG 14.305		Elettrodo O2.....
20-0008	HG 14.306	Diffusore Aria 50-225 A.....	
20-1051	HG 14.307	Ugello 50 A.....	
20-1002	HG 14.308	Protezione.....	
20-1052	HG 14.309	Boccola esterna 50 A.....	

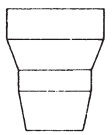
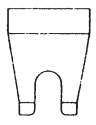
Codice	N° Articolo	Descrizione	
<b>Ricambi compatibili con Thermal Dynamics® PCH/M-40</b>  <b>Pak Master 50XL Plus</b>			
2-5035 2-5036 2-5039 2-5040 4-0815 4-0816 4-2897 4-2898	HG 14.156 HG 14.157 HG 14.158 HG 14.159 HG 14.068 HG 14.069 HG 14.160 HG 14.161	Torcia manuale 25' - 7,5 m..... Torcia manuale 50' - 15 m..... Torcia automatica 25' - 7,5 m..... Torcia automatica 50' - 15 m..... Fascio cavi 25' - 7,5 m torcia manuale..... Fascio cavi 50' - 15 m torcia manuale..... Fascio cavi 25' - 7,5 m torcia automatica..... Fascio cavi 50' - 15 m torcia automatica.....	
8-0533  9-8055 9-8059	HG 1221A  HG 14.162 HG 14.065	 O-ring (per impugnatura).....  Corpo torcia manuale 70°..... Impugnatura completa con pulsante.....	
9-8053 9-7833	HG 14.163 HG 14.164	 Corpo torcia automatica 180°..... Tubo di posizionamento.....	
9-6506	HG 14.023	 Elettrodo Hafnium, rinforzato.....	
9-6507	HG 14.024	 Diffusore Aria - Vespel®.....	
9-6500	HG 14.025	 Ugello rinforzato.....	
9-6501 9-6502	HG 14.026 HG 14.165	 Ugello rinforzato (drag cut)..... Ugello scricatura.....	
9-6003	HG 14.003	 Protezione Std.....	
9-6004	HG 14.004	 Protezione a corona.....  Per il relativo kit compasso per torcia e accessori vedere pagina 3	

## Ricambi compatibili con Thermal Dynamics® PCH/M-75, - 76 e - 100XL

Pak Master 75, Pak Master 75XL, 625XR, Cut Master 80XL, Econopak 100, Pak Master 100XL

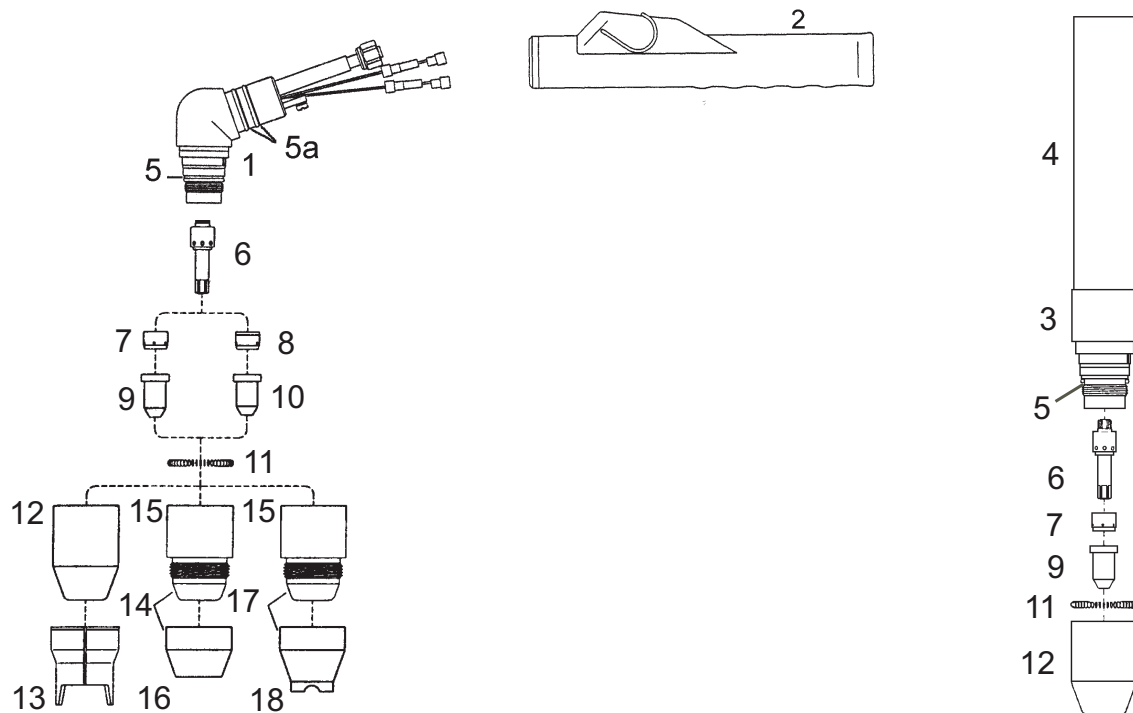

N°	Codice	N° Articolo	Descrizione
	2-7801	HG 14.031	Torcia manuale 25' - 7,5 m (codice compl. 2-7811, 2-0801).....
	2-7802	HG 14.032	Torcia manuale 50' - 15,0 m (codice compl. 2-7812, 2-0802).....
	2-7805	HG 14.050	Torcia automatica 25' - 7,5 m (codice compl. 2-0805).....
	2-7806	HG 14.051	Torcia automatica 50' - 15,0 m (codice compl. 2-0806).....
	4-7801	HG 14.047	Fascio cavi 25' -7,5 m torcia manuale (codice compl. 4-0810, 4-7611)..
	4-7802	HG 14.048	Fascio cavi 50' -15,0 m torcia manuale (codice compl. 4-0811, 4-7612)
	4-7803	HG 14.096	Fascio cavi 25' - 7,5 m torcia automatica (codice compl. 4-0812).....
	4-7804	HG 14.097	Fascio cavi 50' - 15,0 m torcia automatica (codice compl. 4-0813).....
1	8-7510	HG 14.033	Corpo torcia manuale 70°.....
2	9-5636E	HG 14.034	Impugnatura completa con pulsante.....
3	8-7512	HG 14.052	Corpo torcia automatica 180° (non per PCH/M - 76).....
4	9-5637E	HG 14.053	Tubo di posizionamento per torcia automatica (non per PCH/M - 76)...
5	8-0532	HG 1221	O-ring (Protezione).....
5a	8-0533	HG 1221A	O-ring (Impugnatura).....
6	8-7502	HG 14.036	Elettrodo Hafnium.....
7	8-7501	HG 14.037	Diffusore Aria ugelli .....
8	8-7508	HG 14.038	Diffusore Aria ugelli scricatura.....
9	8-7503	HG 14.039	Ugello Ø 0,99 - .039 35 A.....
	8-7504	HG 14.040	Ugello Ø 1,17 - .046 55 A (non PCH/M - 76).....
	8-7505	HG 14.041	Ugello Ø 1,32 - .052 60-70 A (non PCH/M - 75).....
10	8-7506	HG 14.042	Ugello scricatura Ø 1,86 - .073.....
11	9-7501E	HG 14.043	Molla a spirale.....
12	8-7500	HG 14.044	Protezione.....
13	8-7575	HG 14.049	Distanziale a 2 punte.....
14	8-7496	HG 14.174	Protezione completa, lunga durata.....
15	8-7498	HG 14.045	Boccola taglio a contatto.....
16	8-7497	HG 14.098	Protezione taglio automatico (Rame).....
17	8-7507	HG 14.175	Protezione a corona taglio contatto manuale, Set.....
18	8-7499	HG 14.046	Distanziale a corona taglio contatto manuale (Rame).....

Per il relativo kit compasso per torcia e accessori vedere pagina 3

© Copyright 2009 by HOLMA® Switzerland. Tutti i diritti riservati.

Pagina 11