

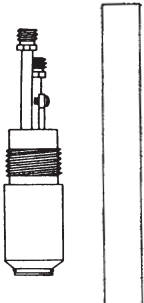









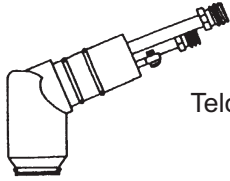





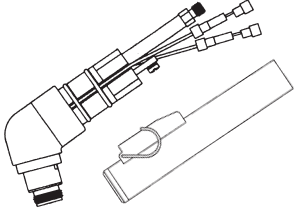





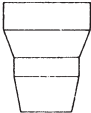

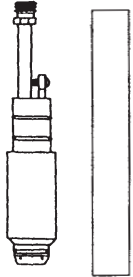
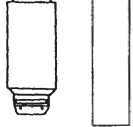
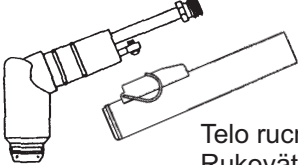



Ref.cislo	Obj.cislo	Popis
		<b>Spotrebne diely vhodne pre Thermal Dynamics® PCH-10 Drag-Gun, Cougar 125</b>
	HG 14.386	Vzduchovy a elektricky kabel 6m.....
2-1020	HG 14.385	Kompletne telo horaka s 6m kablom.....
9-0016 9-0019E	HG 14.063 HG 14.065	Telo horaka (rucneho) 70°..... Rukovät so spinacom.....
8-0533	HG 1221A	O-kruzok na rukovät.....
9-6006	HG 14.007	Elektroda Hafnium.....
9-6007	HG 14.006	Rozvadzac vzduchu - Vespel®.....
9-6099	HG 14.064	Tryska - Vzduch.....
9-6003	HG 14.003	Ochranna krytka.....
		Supravy na kruhove rezanie s prislusenstvom najdete na str. 3
		<b>Spotrebne diely vhodne pre Thermal Dynamics® PCH-25/38 PCH-26 Pak Master 38XL, Drag-Gun 38, Econopak 50</b>
2-0380	HG 14.387	Rucny horak 12,5' - 3,8 m (PCH-25/38).....
2-0381	HG 14.388	Rucny horak 25' - 7,5 m (PCH-25/38).....
4-6067	HG 14.389	Kabel 12,5' - 3,8 m Rucny horak(PCH-25/38).....
4-6068	HG 14.390	Kabel 25' - 7,5 m Rucny horak(PCH-25/38).....
2-3501	HG 14.391	Rucny horak 12,5' - 3,8 m (PCH-26).....
2-3511	HG 14.392	Rucny horak 25' - 7,5 m (PCH-26).....
4-6071	HG 14.067	Kabel 12,5' - 3,8 m Rucny horak (PCH-26).....
4-6072	HG 14.393	Kabel 25' - 7,5 m Rucny horak (PCH-26).....
9-5807 9-6282E	HG 14.028 HG 14.065	Telo horaka (rucneho) 70°..... Rukovät so spinacom.....
8-0533	HG 1221A	O-kruzok na rukovät.....
9-6506	HG 14.023	Elektroda Hafnium, zosilnena.....
9-6507	HG 14.024	Rozvadzac vzduchu, zosilneny.....
9-6501	HG 14.026	Tryska (drag cut), zosilnena.....
9-6003	HG 14.003	Ochranna krytka.....
		Supravy na kruhove rezanie s prislusenstvom najdete na str. 3.



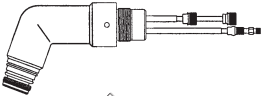
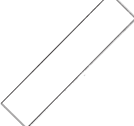
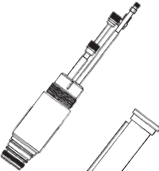

Ref.cislo	Obj.cislo	Popis	
<b>Spotrebne diely vhodne pre Thermal Dynamics® PCH/M- 52</b> <b>Pak-5XR*, Pak-6XR*, Pak-7XR, Pak-8XR, Pak-10-XR, Pak-625XR*</b> <b>Pak-750-XR*, Pak-1000XR, Pak-1250-XR      *=Dual Gas</b>			
2-2936	HG 1446	Horak (rucny) 25' - 7,5 m.....	
2-2937	HG 1447	Horak (rucny) 50' - 15,0 m.....	
2-2938	HG 1448	Horak (strojny) 25' - 7,5 m.....	
2-2939	HG 1449	Horak (strojny) 50' - 15,0 m.....	
4-5034	HG 1463		Kabel 25' - 7,5 m horak (rucny).....
4-5035	HG 1464		Kabel 50' - 15,0 m horak (rucny).....
4-5036	HG 14.131		Kabel 25' - 7,5 m horak (strojny).....
4-5037	HG 14.132		Kabel 50' - 15,0 m horak (strojny).....
9-5643	HG 1429		Telo horaka (strojneho) 180°.....
9-7833	HG 14.133		Dopravna trubica.....
8-5525	HG 1044		O-kruzok (ochranna krytka).....
8-0536	HG 14.397		O-kruzok (rukovät).....
9-5642	HG 1428		Telo horaka (rucneho) 70°.....
9-5644E	HG 14.319		Rukovät so spinacom.....
8-3331	HG 1410		Elektroda-vzduch, long life.....
9-5619	HG 1410/1		Elektroda-Hafnium, niklovana.....
9-5702	HG 1411		Tryska Ø 0,90 mm - .035 35 Amp.....
9-5618	HG 1412		Tryska Ø 1,10 mm - .043 45-55 Amp.....
9-5707	HG 1414		Tryska Ø 1,20 mm - .047 60-70 Amp.....
9-5782	HG 1420		Tryska Ø 1,32 mm - .052 80 Amp.....
9-5708	HG 1415		Tryska Ø 1,50 mm - .059 105 Amp.....
8-5129	HG 1427		Drazkovacia tryska.....
9-5709	HG 1413		Drazkovacia tryska Ø 1,99 mm - .078 70 Amp.....
9-5710	HG 1416		Drazkovacia tryska Ø 2,36 mm - .093 105 Amp.....
9-5713	HG 1417		Drazkovacia tryska Ø 2,87 mm - .113 105 Amp.....
9-5617	HG 1418		
9-5781	HG 1426	Ochranna krytka, Phenolic.....	
9-5799	HG 1498	Ochranna krytka, kovova.....	
9-5780	HG 1421		Korunkova ochranna krytka, kovova..... (Pouzitelna len s HG 1426)
9-5694	HG 1419		Korunkova ochranna krytka, keramicka.....

Supravy na kruhove rezanie s prislusenstvom najdete na str.3

Ref.cislo	Obj.cislo	Popis
		<b>Spotrebne diely vhodne pre Thermal Dynamics® PCH/M-28 a PCH/M-35</b>  <b>Pak Master 50XL, Pak Master 50, Stak Pak</b>
2-5801 2-5802 4-2995 4-2996	HG 14.029 HG 14.030 HG 14.402 HG 14.403	Rucny horak 25' - 7,5 m (PCH/M-28)..... Rucny horak 50' - 15,0 m (PCH/M-28)..... Kabel 25' - 7,5 m na rucny horak (PCH/M-28)..... Kabel 50' - 15 m na rucny horak (PCH/M-28).....
8-0533 9-5807 9-6291E/8-4305E	HG 1221A HG 14.028 HG 14.065	 O-kruzok (na rukovät)..... Telo rucneho horaka70°..... Rukovät so spinacom.....
9-6006 9-6506	HG 14.007 HG 14.023	 Elektroda Hafnium (len PCH/M - 35)..... Elektroda Hafnium, zosilnena.....
9-6007 9-6507	HG 14.006 HG 14.024	 Rozvadzac vzduchu (len PCH/M - 35)..... Rozvadzac vzduchu, zosilneny.....
9-6000 9-6500 9-6002	HG 14.000 HG 14.025 HG 14.002	 Tryska Ø 0,78 mm -.030, 35A vzduch (len PCH/M - 35) Tryska Ø 0,78 mm, zosilnena..... Drazkovacia tryska (len PCH/M - 35).....
9-6001 9-6501	HG 14.001 HG 14.026	 Tryska (drag cut - vzduch) len PCH/M - 35..... Tryska (drag cut - vzduch), zosilnena.....
9-6503	HG 14.027	 Ochranna krytka (zosilnena)..... (Pouzitelna len s HG14.003)
9-6003	HG 14.003	 Ochranna krytka Std.....
9-6004	HG 14.004	 Korunkova krytka..... (Pouzitelna len s HG14.003)
		Supravy na kruhove rezanie s prislusenstvom najdete na str.3
		© Copyright 2009 by HOLMA® Switzerland. Vsetky prava vyhradene..

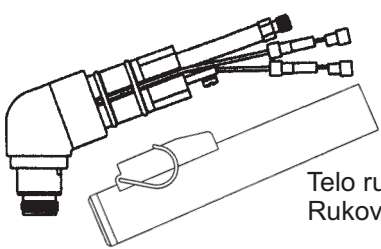
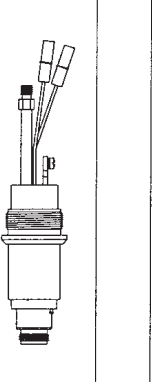
Ref.cislo	Obj.cislo	Popis	
<b>Spotrebne diely vhodné pre Thermal Dynamics® PCH/M-51</b>			
<b>4Xi, 6Xi, Pak-3XR, Pak-6XR, Pak-7XR, Pak-5XT, Pak-625XR, Pak-750XR</b>			
2-2860 2-2861 2-2864 2-2865 4-5030 4-5031 4-5032 4-5033	HG 1438 HG 1439 HG 14.127 HG 14.128 HG 1442 HG 1443 HG 14.129 HG 14.130	 <p>Rucny horak 25' - 7,5 m, 9/16-spojenie..... Rucny horak 50' - 15,0 m, 9/16-spojenie..... Strojny horak 25' - 7,5 m..... Strojny horak 50' - 15 m..... Kabel 25'- 7,5 m na rucny horak..... Kabel 50'-15,0 m na rucny horak..... Kabel 25'- 7,5 m na strojny horak..... Kabel 50'-15,0 m na strojny horak.....</p>	
9-5634 9-5637E	HG 1408 HG 14.053	 <p>Telo strojneho horaka 180°..... Dopravna trubica.....</p>	
8-5525 8-0533	HG 1044 HG 1221A	<p>O-kruzok (na ochrannu krytku)..... O-kruzok (na Rukovät).....</p>	
9-5635 9-5636E	HG 1407 HG 14.065	 <p>Telo rucneho horaka 70° ..... Rukovät so spinacom.....</p>	
9-5633 9-5720	HG 1400 HG 1405	 <p>Elektroda Hafnium..... Elektroda Hafnium (4x1).....</p>	
9-5718 9-5631 8-3321 9-5724	HG 1425 HG 1401 HG 14.401 HG 1404	 <p>Tryska Ø 0,96 - .038 10 - 40 Amp..... Tryska Ø 1,10 - .043 10 - 60 Amp..... Tryska Ø 1,20 - .047 - 65 Amp..... Drazkovacia tryska Ø 2,00 - .078.....</p>	
9-5630 8-2159	HG 1402 HG 1423	 <p>Ochranna krytka, keramicka..... Ochranna krytka, Phenolic Std.....</p>	
9-5779	HG 1424	 <p>Korunkova krytka, kovova..... (Pouzitelna len s HG1423)</p>	
8-5526	HG 1403	 <p>Korunkova krytka, keramicka.....</p>	
Supravy na kruhove rezanie s prislušenstvom najdete na str.4			
<b>Strana 8</b>			
© Copyright 2009 by HOLMA® Switzerland. Všetky práva vyhradené.			

Ref.cislo	Obj.cislo	Popis		
<b>Spotrebne diely vhodne pre Thermal Dynamics® Maximizer 300</b> <b>Merlin 1000, Merlin 3000, Merlin 6000, Merlin 6000 GST</b>				
9-6457	HG 14.276		Telo rucneho horaka 70°.....	
9-6459	HG 14.277		Telo rucneho horaka 90°.....	
8-0538	HG 14.398		O-kruzok.....	
9-6769	HG 14.278		Upevnujuca trubica.....	
9-6767	HG 14.279		Adapter.....	
9-6410	HG 14.189		Telo strojneho horaka 180°.....	
7-3207	HG 14.152		Dopravna trubica (na Merlin 1000).....	
8-4204	HG 14.102		Krytka na koncovku (für Merlin 1000).....	
8-2158	HG 14.151		Adapter (na Merlin 1000).....	
20-1010	HG 14.282		Elektroda O2 100-225A (na 3000, 6000 & GST).....	
20-1015	HG 14.283		Elektroda O2 100A (na 3000 & 6000).....	
20-1016	HG 14.284		Elektroda O2 150A (na 1000, 3000 & 6000).....	
20-1017	HG 14.285		Elektroda O2 225A (na 3000 & 6000).....	
20-1018	HG 14.261		Elektroda vzduch/O2 50-225A (na vsetky).....	
20-1021	HG 14.286		Elektroda vzduch/O2 300A (na 3000, 6000 & GST).....	
20-1023	HG 14.287		Elektroda N2 50-300A (na vsetky).....	
20-1025	HG 14.288		Elektroda Ar/H2 100-300A (na vsetky).....	
20-0008	HG 14.306			Rozvzadzac vzduchu 50-225 Amp (na vsetky).....
20-1009	HG 14.291			Rozv. vzduchu 300 Amp (na 3000, 6000 & GST).....
20-1030	HG 14.292		Tryska 50 Amp O2/N2/Air (na vsetky).....	
20-1031	HG 14.293		Tryska 100 Amp O2/N2/Air (na vsetky).....	
20-1032	HG 14.294		Tryska 150 Amp (na 3000, 6000 & GST).....	
20-1033	HG 14.295		Tryska 225 Amp (na 3000, 6000 & GST).....	
20-1034	HG 14.296		Tryska 300 Amp (na vsetky).....	
20-1002	HG 14.308		Ochranna krytka (na vsetky).....	
20-1029	HG 14.298		Ochranna krytka (na 1000, 6000 & GST).....	
20-1003	HG 14.299		Krytka na koncovku 50 Amp (na vsetky).....	
20-1004	HG 14.300		Krytka na koncovku 100-225 Amp (na vsetky).....	
20-1005	HG 14.301		Krytka na koncovku 300Amp (na 3000, 6000 & GST).....	
20-1006	HG 14.302		Krytka na koncovku 100-300 Amp (6000, GST).....	
20-1007	HG 14.303		Krytka na koncovku (na 3000, 6000 & GST).....	
20-1028	HG 14.304		Krytka na koncovku (na 6000).....	
<b>Square Cut, 50A, O2-O2 Spotrebne diely:</b>				
20-1050	HG 14.305		Elektroda O2.....	
20-0008	HG 14.306	Rozvzadzac vzduchu 50-225 Amp.....		
20-1051	HG 14.307	Tryska 50 Amp.....		
20-1002	HG 14.308	Ochranna krytka.....		
20-1052	HG 14.309	Viecko na krytku 50 Amp.....		

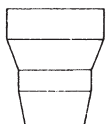
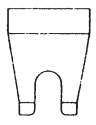
Ref.cislo	Obj.cislo	Popis	
<b>Spotrebne diely vhodne pre Thermal Dynamics® PCH/M-40</b>			
<b>Pak Master 50XL Plus</b>			
2-5035 2-5036 2-5039 2-5040 4-0815 4-0816 4-2897 4-2898	HG 14.156 HG 14.157 HG 14.158 HG 14.159 HG 14.068 HG 14.069 HG 14.160 HG 14.161	Rucny horak 25' - 7,5 m..... Rucny horak 50' - 15 m..... Strojny horak 25' - 7,5 m..... Strojny horak 50' - 15 m..... Kabel 25' - 7,5 m na rucny horak..... Kabel 50' - 15 m na rucny horak..... Kabel 25' - 7,5 m na strojny horak..... Kabel 50' - 15 m na strojny horak.....	
8-0533  9-8055 9-8059	HG 1221A  HG 14.162 HG 14.065	 O-kruzok na rukovät .....  Telo rucneho horaka 70°..... Rukovät so spinacom.....	
9-8053 9-7833	HG 14.163 HG 14.164	 Telo strojneho horaka 180°..... Dopravna trubica.....	
9-6506	HG 14.023	 Elektroda Hafnium, zosilnena.....	
9-6507	HG 14.024	 Rozvadzac vzduchu - Vespel®.....	
9-6500	HG 14.025	 Tryska zosilnena.....	
9-6501 9-6502	HG 14.026 HG 14.165	 Tryska zosilnena (drag cut)..... Drazkovacia tryska.....	
9-6003	HG 14.003	 Ochranna krytka Std.....	
9-6004	HG 14.004	 Korunkova krytka.....  Supravy na kruhove rezanie najdete na str. 3	

## Spotrebne diely vhodne pre Thermal Dynamics® PCH/M-75, - 76 a - 100XL

Pak Master 75, Pak Master 75XL, 625XR, Cut Master 80XL, Econopak 100, Pak Master 100XL

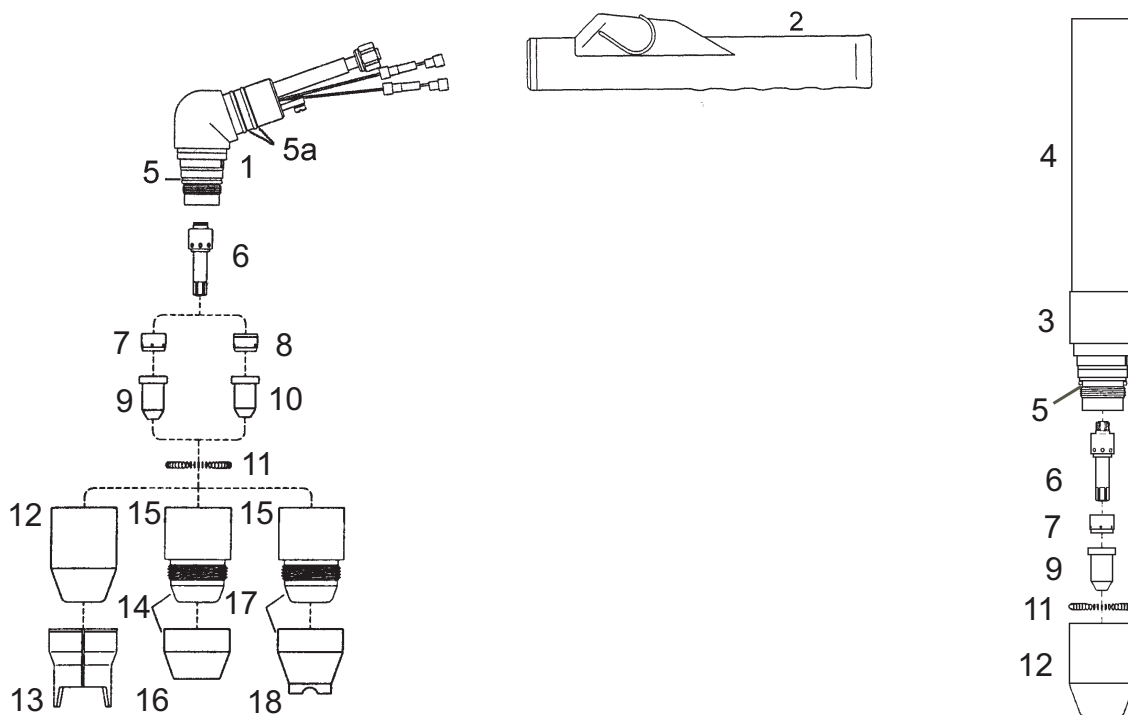

C.	Ref.cislo	Obj.cislo	Popis
	2-7801	HG 14.031	Rucny horak 25' - 7,5 m (dodat.ref.c. 2-7811, 2-0801).....
	2-7802	HG 14.032	Rucny horak 50' - 15,0 m (dodat.ref.c. 2-7812, 2-0802).....
	2-7805	HG 14.050	Strojny horak 25' - 7,5 m (dodat.ref.c. 2-0805).....
	2-7806	HG 14.051	Strojny horak 50' - 15,0 m (dodat.ref.c. 2-0806).....
	4-7801	HG 14.047	Kabel 25' - 7,5 m na rucny horak (dodat.ref.c. 4-0810, 4-7611).....
	4-7802	HG 14.048	Kabel 50' - 15,0 m na rucny horak (dodat.ref.c. 4-0811, 4-7612).....
	4-7803	HG 14.096	Kabel 25' - 7,5 m na strojny horak (dodat.ref.c. 4-0812).....
	4-7804	HG 14.097	Kabel 50' - 15,0 m na strojny horak (dodat.ref.c. 4-0813).....
1	8-7510	HG 14.033	Telo rucneho horaka 70°.....
2	9-5636E	HG 14.034	Rukovät so spinacom.....
3	8-7512	HG 14.052	Telo strojneho horaka 180° (nie na PCH/M - 76).....
4	9-5637E	HG 14.053	Dopravna trubica na strojny horak (nie na PCH/M - 76).....
5	8-0532	HG 1221	O-kruzok (Ochranna krytka).....
5a	8-0533	HG 1221A	O-kruzok (Rukovät).....
6	8-7502	HG 14.036	Elektroda Hafnium.....
7	8-7501	HG 14.037	Rozvadzac vzduchu na rezacie trysky.....
8	8-7508	HG 14.038	Rozvadzac vzduchu na drazkovacie trysky.....
9	8-7503	HG 14.039	Tryska Ø 0,99 - .039 35 Amp.....
	8-7504	HG 14.040	Tryska Ø 1,17 - .046 55 Amp (nie na PCH/M - 76).....
	8-7505	HG 14.041	Tryska Ø 1,32 - .052 60-70 Amp (nie na PCH/M - 75).....
10	8-7506	HG 14.042	Dravkovacia tryska Ø 1,86 - .073.....
11	9-7501E	HG 14.043	Pruzina.....
12	8-7500	HG 14.044	Ochranna krytka.....
13	8-7575	HG 14.049	Distancny kruzok, 2 hroty.....
14	8-7496	HG 14.174	Ochranna krytka.....
15	8-7498	HG 14.045	Kontaktna krytka.....
16	8-7497	HG 14.098	Telo krytky (medene).....
17	8-7507	HG 14.175	Suprava korunkovych krytiek.....
18	8-7499	HG 14.046	Korunkova krytka (medena).....

Supravy na kruhove rezanie s prislusenstvom najdete na str. 3

© Copyright 2009 by HOLMA® Switzerland. Vsetky prava vyhradene.

Strana 11